



# **KINGS**

## **ENGINEERING COLLEGE**

**An Autonomous Institution**

**Affiliated to Anna University, Chennai**

### **DEPARTMENT OF MECHANICAL ENGINEERING**

**Regulation 2024**

**III Year – Vth Semester**

**ME243503- Heat and Mass Transfer**

**ME243503- HEAT AND MASS TRANSFER**

**REGULATIONS 2024**

**III YEAR/ V SEMESTER**

**COURSE OBJECTIVE**

- To understand the mechanisms of heat transfer under steady and transient conditions.
- To understand the concepts of heat transfer through extended surfaces.
- To learn the thermal analysis and sizing of heat exchangers and to understand the basic concepts of mass transfer.

(Use of standard HMT data book permitted)

**UNIT I CONDUCTION 9**

General Differential equation of Heat Conduction– Cartesian and Polar Coordinates – One Dimensional Steady State Heat Conduction — plane and Composite Systems – Conduction with Internal Heat Generation – Extended Surfaces – Unsteady Heat Conduction – Lumped Analysis – Semi Infinite and Infinite Solids –Use of Heisler’s charts.

**UNIT II CONVECTION 9**

Free and Forced Convection – Hydrodynamic and Thermal Boundary Layer. Free and Forced Convection during external flow over Plates and Cylinders and Internal flow through tubes.

**UNIT III PHASE CHANGE HEAT TRANSFER AND HEAT EXCHANGERS 9**

Nusselt’s theory of condensation – Regimes of Pool boiling and Flow boiling. Correlations in boiling and condensation. Heat Exchanger Types – Overall Heat Transfer Coefficient – Fouling Factors – Analysis – LMTD method – NTU method

**UNIT IV RADIATION 9**

Black Body Radiation – Grey body radiation – Shape Factor – Electrical Analogy – Radiation Shields. Radiation through gases. Basic Concepts – Diffusion Mass Transfer – Fick’s Law of Diffusion – Steady state Molecular Diffusion – Convective Mass Transfer – Momentum, Heat and Mass Transfer Analogy – Convective Mass Transfer Correlations

**UNIT V MASS TRANSFER 9**

Basic Concepts – Diffusion Mass Transfer – Fick’s Law of Diffusion – Steady state Molecular Diffusion – Convective Mass Transfer – Momentum, Heat and Mass Transfer Analogy – Convective Mass Transfer Correlations.

**TOTAL:45 HOURS**

**OUTCOMES**

Upon successful completion of the course, students will be able to:

1. Apply heat conduction equations to different surface configurations under steady state and transient conditions and solve problems

2. Apply free and forced convective heat transfer correlations to internal and external flows through/over various surface configurations and solve problems
3. Explain the phenomena of boiling and condensation, apply LMTD and NTU methods of thermal analysis to different types of heat exchanger configurations and solve problems
4. Explain basic laws for radiation and apply these principles to radiative heat transfer between different types of surfaces to solve problems
5. Apply diffusive and convective mass transfer equations and correlations to solve problems for different applications
6. Apply heat transfer and mass transfer concepts in industrial applications.

#### TEXT BOOKS

1. R.C. Sachdeva, "Fundamentals of Engineering Heat & Mass transfer", New Age International Publishers, 2009.
2. Yunus A. Cengel, "Heat Transfer A Practical Approach", Tata McGraw Hill, 5th Edition 2015

#### REFERENCE BOOKS

1. Frank P. Incropera and David P. Dewitt, "Fundamentals of Heat and Mass Transfer", John Wiley & Sons, 1998.
2. Kothandaraman, C.P., "Fundamentals of Heat and Mass Transfer", New Age International, New Delhi, 1998.
3. Nag, P.K., "Heat Transfer", Tata McGraw Hill, New Delhi, 2002
4. Ozisik, M.N., "Heat Transfer", McGraw Hill Book Co., 1994.
5. Holman, J.P., "Heat and Mass Transfer", Tata McGraw Hill, 2000

#### CO's – PO's & PSO's MAPPING:

	PO1	PO2	PO3	PO4	PO5	PO6	PO7	PO8	PO9	PO10	PO11	PO12	PSO1	PSO2
<b>CO1</b>	3	2	1	1	1	-	-	-	-	-	-	1	1	2
<b>CO2</b>	3	2	1	2	1	-	-	-	-	-	-	1	1	2
<b>CO3</b>	3	2	1	1	1	-	-	-	-	-	-	1	1	2
<b>CO4</b>	3	2	1	1	-	-	-	-	-	-	-	1	1	2
<b>CO5</b>	3	2	3	2	1	-	-	1	-	-	-	1	1	2
<b>CO6</b>	3	2	1	1	-	-	-	-	-	-	-	1	1	1

1 – low; 2 – medium; 3 - high

# UNIT 1

## UNIT: I - CONDUCTION

### Fourier's Law of conduction.

The rate of heat conduction is proportional to the area measured – normal to the direction of heat flow and to the temperature gradient in that direction.

$$Q \propto -A \frac{dt}{dx}$$
$$Q = -KA \frac{dt}{dx}$$

Where, A are in m<sup>2</sup>

$\frac{dt}{dx}$  is temperature gradient in K/m

K is Thermal Conductivity W/mk

### Newton's law of cooling or convection law.

Heat transfer by convection is given by Newton's law of cooling

$$Q = hA (T_s - T_\infty)$$

Where

A – Area exposed to heat transfer in m<sup>2</sup>, h - heat transfer coefficient in W/m<sup>2</sup>K

T<sub>s</sub> – Temperature of the surface in K, T<sub>∞</sub> - Temperature of the fluid in K.

### Overall heat transfer co-efficient.

The overall heat transfer by combined modes is usually expressed in terms of an overall conductance or overall heat transfer co-efficient 'U'.

$$\text{Heat transfer } Q = UA \Delta T.$$

### Equation for heat transfer through composite pipes or cylinder.

$$\text{Heat transfer } Q = \frac{\Delta T_{\text{overall}}}{R} \text{ where } \Delta T = T_a - T_b$$

$$R = \frac{1}{2\pi L} \cdot \frac{1}{h_a r_1} + \frac{\ln\left[\frac{r_2}{r_1}\right]}{K_1} + \frac{\ln\left[\frac{r_1}{r_2}\right]}{K_1} L_2 + \frac{1}{h_a r_{12}}$$

### **critical radius of insulation (or) critical thickness?**

Critical radius =  $r_c$  Critical thickness =  $r_c - r_1$

Addition of insulating material on a surface does not reduce the amount of heat transfer rate always. In fact under certain circumstances it actually increases the heat loss up to certain thickness of insulation. The radius of insulation for which the heat transfer is maximum is called critical radius of insulation, and the corresponding thickness is called critical thickness.

### **Fin efficiency and Fin effectiveness.**

The efficiency of a fin is defined as the ratio of actual heat transfer by the fin to the maximum possible heat transferred by the fin.

$$\eta = \frac{Q_{fin}}{Q_{max}}$$

Fin effectiveness is the ratio of heat transfer with fin to that without fin

$$fin\ effectiveness = \frac{Q_{withfin}}{Q_{withoutfin}}$$

### **critical thickness of insulation with its significance.**

Addition of insulating material on a surface does not reduce the amount of heat transfer rate always. In fact under certain circumstances it actually increases the heat loss up to certain thickness of insulation. The radius of insulation for which the heat transfer is maximum is called critical radius of insulation, and the corresponding thickness is called critical thickness. For cylinder, Critical radius =  $r_c = k/h$ , Where  $k$ - Thermal conductivity of insulating material,  $h$ - heat transfer coefficient of surrounding fluid. Significance: electric wire insulation may be smaller than critical radius. Therefore the plastic insulation may actually enhance the heat transfer from wires and thus keep their steady operating temperature at safer levels.

## **lumped system analysis? When is it applicable?**

In heat transfer analysis, some bodies are observed to behave like a "lump" whose entire body temperature remains essentially uniform at all times during a heat transfer process. The temperature of such bodies can be taken to be a function of time only. Heat transfer analysis which utilizes this idealization is known as the lumped system analysis. It is applicable when the Biot number (the ratio of conduction resistance within the body to convection resistance at the surface of the body) is less than or equal to 0.1.

## **three dimensional heat transfer poisson and laplace equation in Cartesian co-ordinates**

Poisson equation:

$$\frac{\partial^2 T}{\partial x^2} + \frac{\partial^2 T}{\partial y^2} + \frac{\partial^2 T}{\partial z^2} + \frac{g}{k} = 0$$

Laplace equation:

$$\frac{\partial^2 T}{\partial x^2} + \frac{\partial^2 T}{\partial y^2} + \frac{\partial^2 T}{\partial z^2} = 0$$

**10. A 3 mm wire of thermal conductivity 19 W/mK at a steady heat generation of 500 MW/m<sup>3</sup>. Determine the center temperature if the outside temperature is maintained at 25°C**

$$\begin{aligned} \text{Critical temperature} \quad T_c &= T_\infty + \frac{qr^2}{4K} \\ &= 298 + \left[ \frac{500 \times 10^6 \times 0.0015^2}{4 \times 19} \right] \\ T_c &= 312.8K \end{aligned}$$

**the three types of boundary conditions.**

1. Prescribed temperature
2. Prescribed heat flux
3. Convection Boundary Conditions.

**fins (or) extended surfaces.**

It is possible to increase the heat transfer rate by increasing the surface of heat transfer. The surfaces used for increasing heat transfer are called extended surfaces or sometimes known as fins.

**thermodynamics differ from heat transfer?**

- Thermodynamics doesn't deals with rate of heat transfer
- Thermodynamics doesn't tell how long it will occur
- Thermodynamics doesn't tell about the method of heat transfer

**1. Derive the General Differential Equation of Heat Conduction in Cartesian coordianates.(NOV/DEC 2014)**

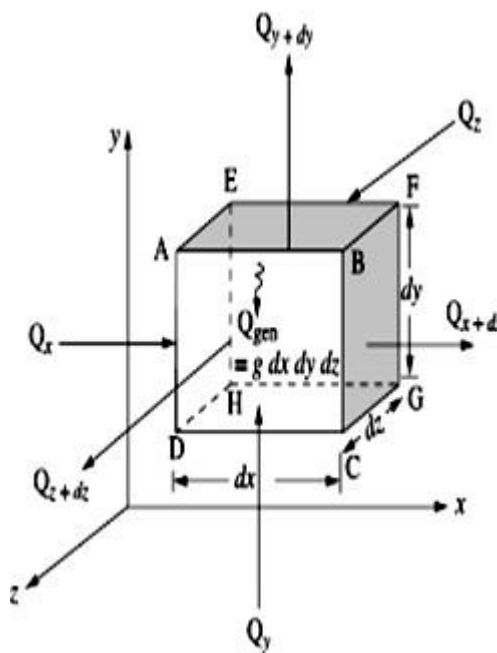

**Fig 2.1**

Consider a small volume element in Cartesian coordinates having sides dx, dy and dz as shown in Fig. 2.1 the energy balance for this little element is obtained from the first law of thermodynamics as:

$$\left\{ \begin{array}{l} \text{Net heat conducted into element} \\ dx dy dz \text{ per unit time} \\ (I) \end{array} \right\} + \left\{ \begin{array}{l} \text{Internal heat generated} \\ \text{per unit time} \\ (II) \end{array} \right\}$$

$$= \left\{ \begin{array}{l} \text{Increase in internal} \\ \text{per unit time} \\ \text{(III)} \end{array} \right\} + \left\{ \begin{array}{l} \text{Work done by element} \\ \text{per unit time} \\ \text{(IV)} \end{array} \right\} \quad (2.2)$$

The last term of Eqn. (2.2) is very small because the flow work done by solids due to temperature changes is negligible.

The three terms, I, II and III of this equation are evaluated as follows:

Let  $q_x$  be the heat flux in x-direction at x, face ABCD and  $q_{x+dx}$  the heat flux at  $x + dx$ , face A'B'C'D'. Then rate of heat flow into the element in x-direction through face ABCD is:

$$Q_x = q_x dydz = -k_x \frac{\partial T}{\partial x} dydz \quad (2.3)$$

Where  $k_x$  is the thermal conductivity of material in x-direction and  $\frac{\partial T}{\partial x}$  is the temperature gradient in

x-direction. The rate of heat flow out of the element in x-direction through the face at  $x+dx$ . A'B'C'D' is:

$$Q_x = -k_x \frac{\partial T}{\partial x} dydz - \frac{\partial}{\partial x} \left( k_x \frac{\partial T}{\partial x} \right) dx dydz \quad (2.4)$$

Then, the net rate of heat entering the element in x-direction is the difference between the entering and leaving heat flow rates, and is given by:

$$Q_x - Q_{x+dx} = \frac{\partial}{\partial x} \left( k_x \frac{\partial T}{\partial x} \right) dx dydz \quad (2.5)$$

$$Q_y - Q_{y+dy} = \frac{\partial}{\partial y} \left( k_y \frac{\partial T}{\partial y} \right) dx dydz$$

$$Q_z - Q_{z+dz} = \frac{\partial}{\partial z} \left( k_z \frac{\partial T}{\partial z} \right) dx dydz$$

The net heat conducted into the element  $dx dydz$  per unit time, term I in Eqn. (2.2) is:

$$I = \left[ \frac{\partial}{\partial x} \left( k_x \frac{\partial T}{\partial x} \right) + \frac{\partial}{\partial y} \left( k_y \frac{\partial T}{\partial y} \right) + \frac{\partial}{\partial z} \left( k_z \frac{\partial T}{\partial z} \right) \right] dx dydz \quad (2.6)$$

Let  $q$  be the internal heat generation per unit time and per unit volume ( $W/m^3$ ), the rate of energy generation in the element, term II in Eqn. (2.2), is

$$II = q dx dydz \quad (2.7)$$

The change in internal energy for the element over a period of time  $dt$  is: (mass of element) (specific heat) (change in temperature of the element in time  $dt$ )

$$(\rho dx dydz) (c_p) dT = (\rho c_p dT) dx dydz \quad (2.8)$$

Where  $\rho$  and  $c_p$  are the density and specific heat of the material of the element.

Then, the change in internal energy per unit time, term III of Eqn. (2.2) is:

$$\text{III} = \rho c_p \frac{\partial T}{\partial t} dx dy dz \quad (2.9)$$

Substitution of Eqns. (2.6),(2.7) and (2.9) into Eqn. (2.2) leads to the general three-dimensional equation for heat conduction:

$$\frac{\partial}{\partial x} \left( k_x \frac{\partial T}{\partial x} \right) + \frac{\partial}{\partial y} \left( k_y \frac{\partial T}{\partial y} \right) + \frac{\partial}{\partial z} \left( k_z \frac{\partial T}{\partial z} \right) + q = \rho c_p \frac{\partial T}{\partial t} \quad (2.10)$$

Since for most engineering problems the materials can be considered isotropic for which  $K_x = K_y = K_z = k = \text{Constant}$ , the general three-dimensional heat conduction equation becomes:

$$\frac{\partial^2 T}{\partial x^2} + \frac{\partial^2 T}{\partial y^2} + \frac{\partial^2 T}{\partial z^2} + \frac{q}{k} = \frac{\rho c_p}{k} \frac{\partial T}{\partial t} = \frac{1}{\alpha} \frac{\partial T}{\partial t}$$

The quantity  $\frac{k}{\rho c_p}$  is known as the thermal diffusivity,  $\alpha$  of the material. It has got the units  $\text{m}^2/\text{s}$ .

## 2. Derive the Heat conduction equation in cylindrical coordinates.

The heat conduction equation derived in the previous section can be used for solids with rectangular boundaries like slabs, cubes, etc. but then there are bodies like cylinders, tubes, cones, spheres to which Cartesian coordinates system is not applicable.

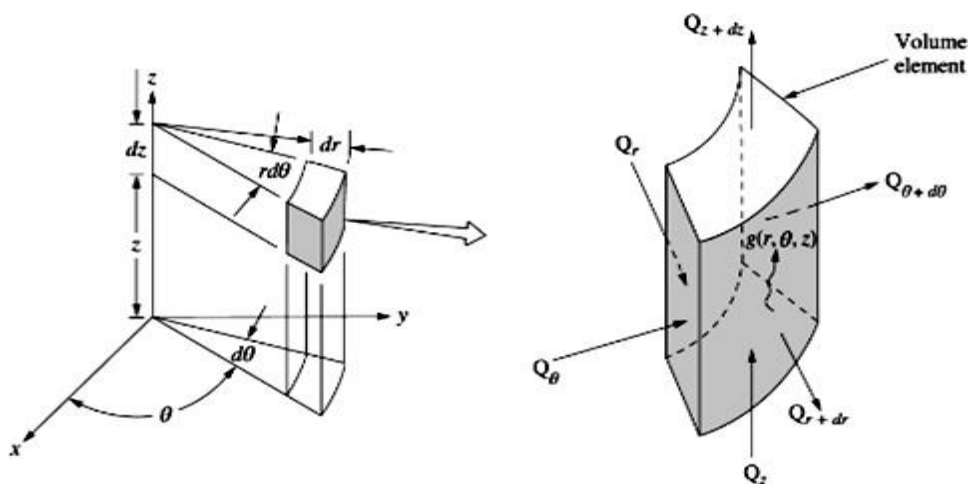

**Fig 2.2**

A more suitable system will be one in which the coordinate surfaces coincide with the boundary surfaces of the region. For cylindrical bodies, a cylindrical

coordinate system should be used. The heat conduction equation in cylindrical coordinates can be obtained by an energy balance over a differential element, a procedure similar to that described previously. The equation could also be obtained by doing a coordinate transformation from Fig. 2.2.

Consider a small volume element having sides  $dr$ ,  $dz$  and  $r d\theta$  as shown in Fig. 2.2. Assuming the material to be isotropic, the rate of heat flow into the element in  $r$ -direction is:

$$Q_r = -k \frac{\partial T}{\partial r} r d\theta dz$$

The rate of heat flow out of the element in  $r$ -direction at  $r+dr$  is:

$$Q_{r+dr} = Q_r + \frac{\partial Q_r}{\partial r} dr$$

Then, the net rate of heat entering the element in  $r$ -direction is given by

$$\begin{aligned} Q_r - Q_{r+dr} &= k \frac{\partial}{\partial r} \left( r \frac{\partial T}{\partial r} \right) dr d\theta dz \\ &= k \left( \frac{\partial^2 T}{\partial r^2} + \frac{1}{r} \frac{\partial T}{\partial r} \right) dr d\theta dz \end{aligned}$$

Similarly,

$$\begin{aligned} Q_\theta - Q_{\theta+d\theta} &= -k \frac{\partial T}{r d\theta} dr dz - \left[ -k \frac{\partial T}{r d\theta} dr dz - \frac{k \partial}{r d\theta} \left( \frac{\partial T}{r \partial \theta} \right) \cdot r d\theta dr dz \right] \\ &= k \left( \frac{1}{r^2} \frac{\partial^2 T}{\partial \theta^2} \right) r dr d\theta dz \\ Q_z - Q_{z+dz} &= -k \frac{\partial T}{\partial z} \cdot r d\theta dz - \left[ -k \frac{\partial T}{\partial z} r d\theta dr - k \frac{\partial}{\partial z} \left( \frac{\partial T}{\partial z} \right) \cdot r d\theta dr dz \right] \\ &= -k \left( \frac{\partial^2 T}{\partial z^2} \right) r dr d\theta dz \end{aligned}$$

The net heat conducted into the element  $dr \cdot r d\theta \cdot dz$  per unit time, term I of Eqn. (2.2)

$$I = k \left( \frac{\partial^2}{\partial r^2} + \frac{1}{r} \frac{\partial}{\partial r} \right) r dr d\theta dz$$

Taking  $q$  as the internal heat generation per unit time and per unit volume, term II of Eqn (2.2) is

$$II = q r dr d\theta dz$$

The change in internal energy per unit time, term III of Eqn. (2.2) is:

$$III = \rho c_p \frac{\partial T}{\partial t} r dr d\theta dz$$

Substitution of terms I, II and III into the energy balance Eqn. (2.2) leads to three-dimensional equation for an isentropic material in cylindrical coordinate system as

$$\frac{\partial^2 T}{\partial r^2} + \frac{1}{r} \left( \frac{\partial T}{\partial r} \right) + \frac{1}{r^2} \frac{\partial^2}{\partial \theta^2} + \frac{\partial^2}{\partial z^2} + \frac{q}{k} = \frac{1}{\alpha} \frac{\partial T}{\partial t}$$

**3. A furnace wall is made up of three layer of thickness 25 cm, 10 cm and 15 cm with thermal conductivities of 1.65 W/mK and 9.2 W/mK respectively. The inside is exposed to gases at 1250<sup>0</sup>c with a convection coefficient of 25 W/m<sup>2</sup> K and the inside surface is at 1100<sup>0</sup>c , the outside surface is exposed to air at 25<sup>0</sup>C with convection coefficient of 12 W/m<sup>2</sup>K .Determine (i) the unknown thermal conductivity (ii)the overall heat transfer coefficient (iii) All the surface temperature.(May/June 2012)**

**Given:**

Thickness  $L_1 = 25 \text{ cm} = 0.25 \text{ m}$

$L_2 = 10 \text{ cm} = 0.1 \text{ m}$

$L_3 = 15 \text{ cm} = 0.15 \text{ m}$

Thermal conductivity ,  $k_1 = 1.65 \text{ W/mK}$ ,

$k_2 = 9.2 \text{ W/mK}$

Inside Gas Temperature ,  $T_a = 1250^0 \text{ c} = 1523 \text{ K}$

$T_b = 25^0 \text{ c} = 298 \text{ K}$

Inner surface temperature ,  $T_1 = 1100^0 \text{ C} = 1373 \text{ K}$

Inside heat transfer coefficient ,  $h_a = 25 \text{ W/m}^2 \text{ K}$

Outside Heat Transfer Coefficient ,  $h_b = 12 \text{ W/m}^2 \text{ K}$

**To find:**

i) The Unknown Thermal Conductivity ,

ii) The Overall Heat Transfer Coefficient

iii) All The Surface Temperature

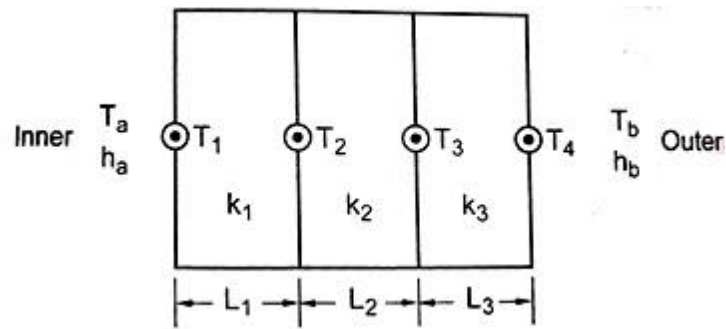

**Solution:**

**STEP-1**

Heat transfer  $Q = h_a A (T_a - T_1)$   
 $= 25(1523 - 1373) = 3750 \text{ W/m}^2$

From HMT data book P.No 45

Heat Flow,  $Q = \Delta T_{\text{overall}} / R$

$$R = \frac{1}{h_a A} + \frac{L_1}{k_1 A} + \frac{L_2}{k_2 A} + \frac{L_3}{k_3 A} + \frac{1}{h_b A}$$

$$Q = \frac{T_a - T_b}{\frac{1}{h_a A} + \frac{L_1}{k_1 A} + \frac{L_2}{k_2 A} + \frac{L_3}{k_3 A} + \frac{1}{h_b A}}$$

$$\frac{Q}{A} = \frac{1523 - 298}{\frac{1}{25} + \frac{0.25}{1.65} + \frac{0.10}{k_2} + \frac{0.15}{9.2} + \frac{1}{12}}$$

$k_2 = 2.816 \text{ W/mk}$

**STEP-2**

From HMT data book P.No 45

Overall Thermal resistance (R)

$$R = \frac{1}{h_a A} + \frac{L_1}{k_1 A} + \frac{L_2}{k_2 A} + \frac{L_3}{k_3 A} + \frac{1}{h_b A}$$

[Take  $A = 1 \text{ m}^2$ ]

$R_{\text{total}} = 0.3267 \text{ W/m}^2$

$U = 1/R_{\text{total}} = 1/0.3267 = 3.06 \text{ W/m}^2\text{K}$

### STEP-3

$$Q = \frac{T_a - T_1}{R_a} = \frac{T_1 - T_2}{R_1} = \frac{T_2 - T_3}{R_2} = \frac{T_3 - T_4}{R_3} = \frac{T_4 - T_b}{R_b}$$

$$Q = \frac{T_a - T_1}{R_a},$$

$$Q = \frac{T_1 - T_2}{R_1},$$

$$R_1 = \frac{L_1}{K_1} = 0.1515$$

$$3750 = \frac{1373 - T_2}{0.1515}$$

$T_2 = 804.8\text{K}$
-----------------------

$$Q = \frac{T_2 - T_3}{R_2} \left[ \because R_2 = \frac{L_2}{K_2} \right]$$

$$3750 = \frac{804.8 - T_3}{\frac{0.10}{2.816}}$$

$T_3 = 671.45\text{K}$
------------------------

$$Q = \frac{T_3 - T_4}{R_3} \left[ \because R_3 = \frac{L_3}{K_3} \right]$$

$$3750 = \frac{671.45 - T_4}{\frac{0.15}{9.2}}$$

$T_4 = 610.30\text{K}$
------------------------

4. A furnace wall consists of 200mm layer of refractory bricks, 6 mm layer of steel plate and a 100mm layer of insulation bricks. The maximum temperature of the wall is 1150°C on the furnace side and the minimum temperature is 40°C on the outermost side of the wall. An accurate energy balance over the furnace shows that the heat loss from the wall is 400W/m<sup>2</sup>. It is known that there is a thin layer of air between the layers of refractory bricks and steel plate. Thermal conductivities for the three layers are 1.52, 45 and 0.138 W/m°C respectively. Find

- i) To how many millimeters of insulation bricks is the air layer equivalent?  
 ii) What is the temperature of the outer surface of the steel plate? (Nov/Dec 2014)

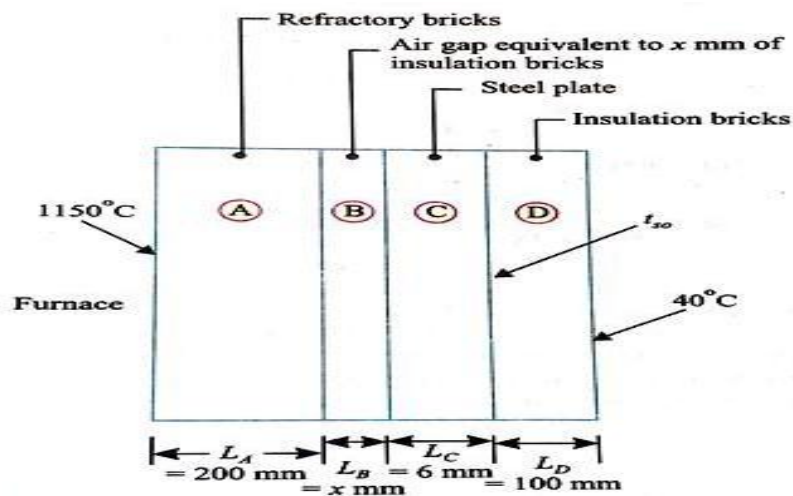

**Given**

Thickness of refractory bricks,  $L_A = 200 \text{ mm} = 0.2 \text{ m}$

Thickness of steel plate,  $L_C = 6 \text{ mm} = 0.006 \text{ m}$

Thickness of insulation bricks,  $L_D = 100 \text{ mm} = 0.1 \text{ m}$

Difference of temperature between the innermost and outermost sides of the wall,

$$\Delta t = 1150 - 40 = 1110^\circ\text{C}$$

$$K_A = 1.52 \text{ W/m}^\circ\text{C}$$

$$K_B = K_D = 0.138 \text{ W/m}^\circ\text{C}$$

$$K_C = 45 \text{ W/m}^\circ\text{C}$$

Heat loss from the wall,  $q = 400 \text{ W/m}^2$

- i) The value of  $x (= L_B)$

From HMT data book P.No 45

Heat Flow,  $Q = \Delta T_{\text{overall}} / R$

$$R = \frac{1}{H_a A} + \frac{L_1}{k_1 A} + \frac{L_2}{k_2 A} + \frac{L_3}{k_3 A} + \frac{1}{H_b A}$$

$$400 = \frac{1110}{\frac{L_A}{K_A} + \frac{L_B}{K_B} + \frac{L_C}{K_C} + \frac{L_D}{K_D}}$$

$$400 = \frac{1110}{\frac{0.2}{1.52} + \frac{(x/1000)}{0.138} + \frac{0.006}{45} + \frac{0.1}{0.138}}$$

$$= \frac{1110}{0.1316+0.0072x+0.00013+0.7246}$$

$$= \frac{1110}{0.8563+0.0072x}$$

$$0.8563 + 0.0072x = \frac{1110}{400} = 2.775$$

$$x = \frac{2.775-0.8563}{0.0072} = 266.5 \text{ mm}$$

$$x = 266.5 \text{ mm}$$

ii) Temperature of the outer surface of the steel plate  $t_{so}$ :

$$q = 400 = \frac{(t_{so} - 40)}{L_D/K_D}$$

$$400 = \frac{(t_{so} - 40)}{0.1/0.138}$$

$$t_{so} = \frac{400}{1.38} + 40 = 329.8^\circ\text{C}$$

$$t_{so} = 329.8^\circ\text{C}$$

5. A steel pipe line ( $K=50\text{W/mk}$ ) of I.D 110mm is to be covered with two layers of insulation each having a thickness of 50mm. The thermal conductivity of the first insulation material is  $0.06\text{W/mk}$  and that of the second is  $0.12\text{W/mk}$ . Calculate the loss of heat per metre length of pipe and the interface temperature between the two layers of insulation when the temperature of the inside tube surface is  $250^\circ\text{C}$  and that of the outside surface of the insulation is  $50^\circ\text{C}$ . (April/ may 2015)

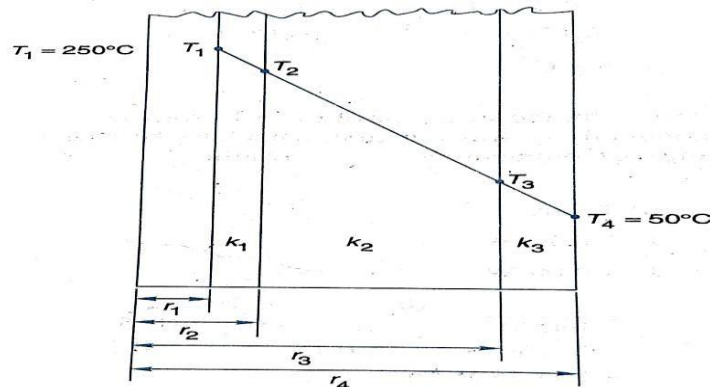

**Given:**

$$r_1 = 50\text{mm}$$

$$r_2 = 55\text{mm}$$

$$r_3 = 105\text{mm}$$

$$r_4 = 155\text{mm}$$

$$K_1 = 50 \frac{W}{mk}$$

$$K_2 = 0.06 \frac{W}{mk}$$

$$K_3 = 0.12 \frac{W}{mk}$$

$$T_1 = 250^\circ\text{C}$$

$$T_4 = 50^\circ\text{C}$$

**To find**

$$T_3 = ?$$

**Solution:**

**step-1**

From HMT data book P.No 46

Heat Flow ,  $Q = \Delta T_{\text{overall}}/R$

$$R = \frac{1}{2\pi L} \left[ \frac{1}{h_a r_1} + \frac{1}{k_1} \ln \left( \frac{r_2}{r_1} \right) + \frac{1}{k_2} \ln \left( \frac{r_3}{r_2} \right) + \frac{1}{k_3} \ln \left( \frac{r_4}{r_3} \right) + \frac{1}{h_b r_4} \right]$$

$$\frac{Q}{L} = \frac{2\pi (T_1 - T_4)}{\frac{\ln \left( \frac{r_2}{r_1} \right)}{K_1} + \frac{\ln \left( \frac{r_3}{r_2} \right)}{K_2} + \frac{\ln \left( \frac{r_4}{r_3} \right)}{K_3}}$$

$$\frac{Q}{L} = \frac{2 \times 3.14 (250 - 50)}{\frac{\ln \left( \frac{55}{50} \right)}{50} + \frac{\ln \left( \frac{105}{55} \right)}{0.06} + \frac{\ln \left( \frac{155}{105} \right)}{0.12}}$$

$\frac{Q}{L} = 89.6 \text{ W/m}$
----------------------------------

**step-2**

The interface temperature,  $T_3$  is obtained from the equation

$$\frac{Q}{L} = \frac{2\pi(T_3 - T_4)}{\frac{\ln\left(\frac{r_4}{r_3}\right)}{K_3}}$$

$$T_3 = \frac{\frac{Q}{L} \times \ln\left(\frac{r_4}{r_3}\right)}{2\pi K_3} + T_4$$

$$= \frac{89.6 \times \ln\left(\frac{155}{105}\right)}{0.12 \times 6.28} + 50$$

$T_3 = 96.3^\circ\text{C}$
----------------------------

6. A plane wall 10cm thick generates heat at a rate of  $4 \times 10^4 \text{ W/m}^3$  when an electric current is passed through it. The convective heat transfer coefficient between each face of the wall and the ambient air is  $50 \text{ W/m}^2\text{K}$ . Determine a) the surface temperature b) the maximum air temperature on the wall, Assume the ambient air temperature to be  $20^\circ\text{C}$  and the thermal conductivity of the wall material to be  $15 \text{ W/mK}$ . (May/June 2016)

**Given:**

Thickness  $L = 10\text{cm} = 0.10\text{m}$

Heat generation  $\dot{q} = 4 \times 10^4 \text{ W/m}^3$

Convective heat transfer co-efficient  $= 50 \text{ W/m}^2\text{K}$ .

Ambient air temperature  $T_\infty = 20^\circ\text{C} + 273 = 293\text{K}$

Thermal conductivity  $k = 15 \text{ W/mK}$ .

**Solution:**

**Step 1**

From HMT data book P.No 48

Surface temperature

$$T_w = T_\infty + \frac{\dot{q}L}{2h}$$

$$= 293 + \frac{4 \times 10^4 \times 0.10}{2 \times 50}$$

$T_w = 333\text{K}$
---------------------

**Step 2**

Maximum temperature

$$T_{max} = T_w + \frac{\dot{q}L^2}{8k}$$

$$= 333 + \frac{4 \times 10^4 \times (0.10)^2}{8 \times 15}$$

$$T_{\max} = 336.3 \text{ K}$$

7. A cylinder 1m long and 5 cm in diameter is placed in an atmosphere at 45°C. It is provided with 10 longitudinal straight fins of material having  $k=120 \text{ W/mK}$ . The height of 0.76mm thick fins is 1.27cm from the cylinder surface. The heat transfer coefficient between cylinder and the atmospheric air is  $17 \text{ W/m}^2\text{K}$ . Calculate the rate of heat transfer and the temperature at the end of fins if the surface temperature of cylinder is 150°C. (Nov/Dec 2015)

**Given:**

Length of cylinder  $W = 1 \text{ m}$

Length of the fin  $L = 1.27 \text{ cm} = 1.27 \times 10^{-2} \text{ m}$ .

Thickness of the fin  $t = 0.76 \text{ mm} = 0.76 \times 10^{-3} \text{ m}$ .

Thermal conductivity  $k = 120 \text{ W/mK} \times 10^{-3}$

heat transfer coefficient  $h = 17 \text{ W/m}^2\text{K}$

Base temperature of the cylinder  $T_b = 150^\circ\text{C} + 273 = 423 \text{ K}$

Ambient temperature  $= 45^\circ\text{C} + 273 = 318 \text{ K}$

Diameter of the cylinder  $d = 5 \text{ cm} = 5 \times 10^{-2} \text{ m}$ .

**To find**

- i) Heat transfer rate,  $Q_{\text{total}}$
- ii) Temperature at the end of the fin,  $T$

**Solution:**

**Step-1**

Perimeter  $= 2W = 2 \times 1 = 2 \text{ m}$

Area  $= Wt = 1 \times 0.76 \times 10^{-3} = 0.76 \times 10^{-3} \text{ m}^2$

From HMT data book P.No 50

$$m = \sqrt{\frac{hp}{kA}}$$

$$= \sqrt{\frac{17 \times 2}{120 \times 0.76 \times 10^{-3}}}$$

$$m = 19.31$$

### Step-2

$$\tan h (mL) = \tanh(19.81 \times 1.27 \times 10^{-2}) = 0.241$$

$$\frac{h}{mk} = \frac{17}{19.31 \times 120} = 0.00734$$

From HMT data book P.No 50

$$Q_{fin} = \sqrt{hpkA} (T_b - T_{\infty}) \left[ \frac{\tanh(ml) + \left(\frac{h}{mk}\right)}{1 + \left(\frac{h}{mk}\right) \tanh(ml)} \right]$$

$$= \sqrt{17 \times 2 \times 120 \times 0.76 \times 10^{-3}} (423 - 318) \left[ \frac{0.241 + (0.00734)}{1 + (0.00734)0.241} \right]$$

$Q_{fin} = 45.65 \text{ KWperfin}$

From HMT data book P.No 44

$$Q_b = h[\pi D - [10 \times 0.76 \times 10^{-3}]L(T_b - T_{\infty})]$$

$$= 17[\pi \times 0.05 - [10 \times 0.76 \times 10^{-3}]1(423 - 318)]$$

$$Q_b = 266.82W$$

### Step-3

$$Q_{total} = 10Q_{fin} + Q_b$$

$$= (10 \times 45.7) + 266.82$$

$$Q_{total} = 723.82W$$

### Step-4

From HMT data book P.No 50

The temperature at the end of the fin

$$T - T_{\infty} = \frac{T_b - T_{\infty}}{\text{Cosh}(ml) + \left(\frac{h}{mk}\right) \sinh(ml)}$$

$$T - 318 = \frac{423 - 318}{\text{Cosh}(19.81 \times 1.27 \times 10^{-2}) + (0.00734) \sinh(19.81 \times 1.27 \times 10^{-2})}$$

$T = 419.74K$

8. A circumferential rectangular fins of 140mm wide and 5mm thick are fitted on a 200mm diameter tube. The fin base temperature is 170°C and the ambient temperature is 25°C. Estimate fin Efficiency and heat loss per fin. Take Thermal conductivity  $K = 220\text{W/mk}$  Heat transfer co-efficient  $h = 140\text{W/m}^2\text{k}$ .

**Given:**

Wide  $L = 140\text{mm} = 0.140\text{m}$

Thickness  $t = 5\text{mm} = 0.005\text{m}$

Diameter  $d = 200\text{mm} \Rightarrow r = 100\text{mm} = 0.100\text{m}$

Fin base temperature  $T_b = 170^\circ\text{C} + 273 = 443\text{K}$

Ambient temperature  $T_\infty = 25^\circ\text{C} + 273 = 298\text{K}$

Thermal conductivity  $k = 220\text{W/mk}$

Heat transfer co-efficient  $h = 140\text{W/m}^2\text{k}$

**To find:**

Fin Efficiency,  $\eta$

Heat loss  $Q$

**Solution:**

A rectangular fin is long and wide. So heat loss is calculated by fin efficiency curves

From HMT data book P.No 52

**Step1**

$$\begin{aligned} \text{Corrected length } L_c &= L + \frac{t}{2} \\ &= 0.140 + \frac{0.005}{2} \end{aligned}$$

$$L_c = 0.1425 \text{ m}$$

**Step2**

$$\begin{aligned} r_{2c} &= r_1 + L_c \\ &= 0.100 + 0.1425 \end{aligned}$$

$$r_{2c} = 0.2425\text{m}$$

**Step 3**

$$A_s = 2\pi [r_{2c}^2 - r_1^2]$$

$$= 2\pi[(0.2425)^2 - (0.100)^2]$$

$$A_s = 0.30650m^2$$

#### Step4

$$A_m = t[r_{2c} - r_1]$$

$$A_m = 0.005[0.2425 - 0.100]$$

$$A_m = 7.125 \times 10^{-4}m^2$$

From the graph, we know that, [HMT data book page no.51]

$$X_{axis} = (L_c)^{1.5} \left[ \frac{h}{KA_m} \right]^{0.5}$$

$$= (0.1425)^{1.5} \left[ \frac{140}{220 \times 7.125 \times 10^{-4}} \right]^{0.5}$$

$$X_{axis} = 1.60$$

$$\text{Curve} \rightarrow \frac{r_{2c}}{r_1} = \frac{0.2425}{0.1} = 2.425$$

$X_{axis}$  value is 1.60

Curve value is 2.425

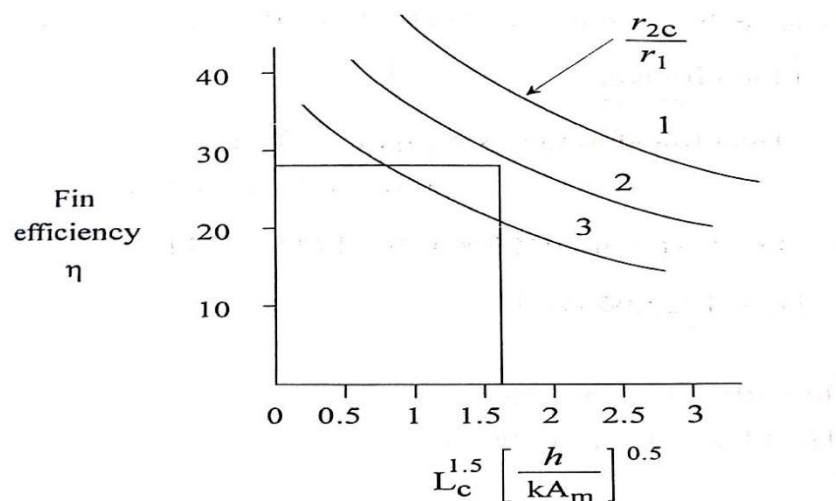

By using these values we can find fin efficiency,  $\eta$  from graph

$$\text{Fin Efficiency } \eta = 28 \%$$

Heat transfer =  $\eta A_s h (T_b - T_\infty)$  from HMT data book P.No 50

$$= 0.28 \times 0.30650 \times 140 \times [443 - 298]$$

$$Q = 1742.99W$$

9. A metallic sphere of radius 10mm is initially at a uniform temperature of 400°C. It is heat treated by first cooling it in air ( $h=10 \text{ W/m}^2\text{k}$ ) at 20°C until its central temperature reaches 335°C . It is then quenched in a water bath at 20°C with  $h=6000 \text{ W/m}^2\text{K}$  until the centre of the sphere cools from 335°C to 50°C. compute the time required for cooling in air and water for the following physical properties of the sphere.

$$\text{Density, } \rho = 3000 \text{ kg/m}^3$$

$$c = 1000 \text{ J/kgK}$$

$$K = 20 \text{ W/mK}$$

$$\alpha = 6.66 \times 10^{-6} \text{ m}^2/\text{s}$$

**Given**

$$\text{Density, } \rho = 3000 \text{ kg/m}^3$$

$$c = 1000 \text{ J/kgK} \quad K = 20 \text{ W/mK}$$

$$\alpha = 6.66 \times 10^{-6} \text{ m}^2/\text{s}$$

**To find**

Surface temperature at end of cooling in water.

**Solution**

**Step-1**

i) Cooling in air .

Let us check whether lumped capacity method can be used here

$$B_i = \frac{hr_0}{3k} = \frac{10 \times 0.01}{3 \times 20} = 16.66 \times 10^{-4} \ll 0.1$$

From HMT data book P.No 58

$$\therefore \frac{T - T_\infty}{T_0 - T_\infty} = \exp \left[ - \left\{ \frac{hA}{\rho c V} \right\} \cdot t \right]$$

$$t = \frac{\rho c V}{hA} \ln \frac{T_0 - T_\infty}{T - T_\infty} = \frac{\rho r_0 c}{3h} \ln \frac{T_0 - T_\infty}{T - T_\infty}$$

$$t = 188s$$

$$= \frac{3000 \times 0.01 \times 1000}{3 \times 10} \ln \frac{400 - 20}{335 - 20}$$

## Step-2

ii) Cooling in water

$$B_i(\text{for lumped capacity method}) = \frac{hr_0}{3k} = \frac{6000 \times 0.01}{3 \times 20} = 1.0 > 0.1$$

So the lumped capacity method cannot be employed, but heisler charts can be used

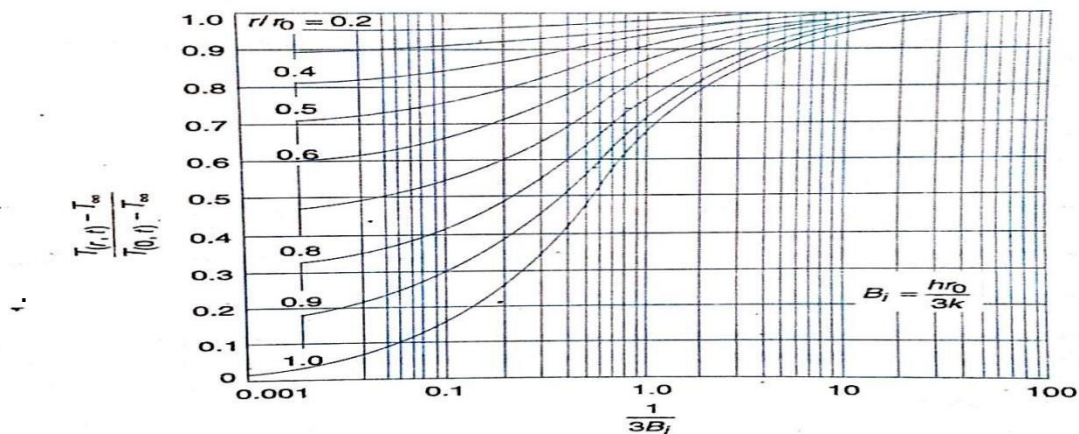

$$\frac{1}{B_i} = \frac{k}{hr_0} = \frac{20}{6000 \times 0.01} = 0.33$$

$$\frac{T_{(0,t)} - T_\infty}{T_0 - T_\infty} = \frac{50 - 20}{335 - 20} = 0.095$$

$$F_o = \frac{\alpha t}{r_0^2} = 0.5$$

$$t = \frac{F_o r_0^2}{\alpha} = \frac{0.5 \times 0.01^2}{6.66 \times 10^{-6}} = 7.5s$$

The surface temperature at the end of quenching in water may be obtained from fig with

$$\frac{1}{3B_i} = 0.33$$

$$\frac{r}{r_0} = 1$$

$$\frac{T(r_0) - T_\infty}{T(0,t) - T_\infty} = 0.33$$

$$T(r_0) = [0.33 \times (50 - 20)] + 20 = 30^\circ\text{C}$$

$$T(r_0) = 30^\circ\text{C}$$

10. A thermocouple junction is in the form of 8 mm diameter sphere. Properties of material are  $c=420 \text{ J/kg}^\circ\text{C}$ ,  $\rho=8000 \text{ kg/m}^3$ ,  $k=40 \text{ W/m}^\circ\text{C}$  and  $h=40 \text{ W/m}^2\text{C}$ . The junction is initially at  $40^\circ\text{C}$  and inserted in a stream of hot air at  $300^\circ\text{C}$ . Find

i) Time constant of the thermocouple

ii) The thermocouple is taken out from the hot air after 10 seconds and kept in still air at  $30^\circ\text{C}$ . Assuming the heat transfer coefficient in air  $10\text{W/m}^2\text{C}$ , find the temperature attained by the junction 20 seconds after removing from hot air.(Nov/Dec 2008)

**Given**

$$R=4 \text{ mm} = 0.004\text{m}$$

$$C= 420 \text{ J/kg}^\circ\text{C}$$

$$\rho=8000 \text{ kg/m}^3$$

$$k=40 \text{ W/m}^\circ\text{C}$$

$$h=40 \text{ W/m}^2\text{C} \text{ (gas stream)}$$

$$h=10 \text{ W/m}^2\text{C} \text{ (gas air)}$$

**To Find**

i) Time constant of the thermocouple  $\tau^*$

ii) The temperature attained by the junction (t)

**Solution**

**Step-1**

$$\tau^* = \frac{\rho VC}{hA_s} = \frac{\rho \times \left[\frac{4}{3}\pi R^3\right] \times c}{h \times 4\pi R^2} = \frac{\rho Rc}{3h}$$

$$\tau^* = \frac{8000 \times 0.004 \times 420}{3 \times 40} = 112 \text{ s}$$

$$\tau^* = 112 \text{ s}$$

## Step-2

$$t_i = 40^\circ\text{C}, t_a = 300^\circ\text{C}, \tau = 10\text{s}$$

The temperature variation with respect to time during heating (when dipped in gas stream) is given by

From HMT data book P.No 58

$$\frac{t - t_a}{t_i - T_a} = \exp \left[ - \left\{ \frac{hA}{\rho c V} \right\} \cdot t \right]$$

$$\frac{t - 300}{40 - 300} = \exp \left[ - \left\{ \frac{\tau}{\tau^*} \right\} \right] = e^{(10/112)}$$

$$\frac{1}{e^{(10/112)}} = 0.9146$$

$$t = 300 + 0.9146(40 - 300) = 62.2^\circ\text{C}$$

$$t = 62.2^\circ\text{C}$$

The temperature variation with respect to time during cooling (when exposed to air) is given by

$$\frac{t - t_a}{t_i - T_a} = e^{-\frac{\tau}{\tau^*}}$$

Where

$$\tau^* = \frac{\rho R c}{3h} = \frac{8000 \times 0.004 \times 420}{3 \times 10} = 448\text{s}$$

$$\frac{t - 30}{62.2 - 30} = e^{-\left(\frac{20}{448}\right)}$$

$$t = 30 + 0.9563(62.2 - 30) = 60.79^\circ\text{C}$$

$$t = 60.79^\circ\text{C}$$

**1. Heat Conduction in the Base Plate of an Iron** Consider the base plate of a 1200-W household iron that has a thickness of  $L = 0.5 \text{ cm}$ , base area of  $A = 300 \text{ cm}^2$ , and thermal conductivity of  $k = 15 \text{ W/m} \cdot ^\circ\text{C}$ . The inner surface of the base plate is subjected to uniform heat flux generated by the resistance heaters inside, and the outer surface loses heat to the surroundings at  $T_\infty = 20^\circ\text{C}$  by convection, as shown in Figure

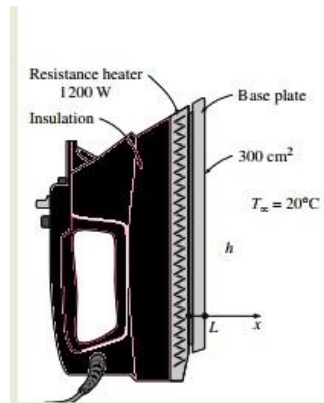

Taking the convection heat transfer coefficient to be  $h = 80 \text{ W/m}^2 \cdot ^\circ\text{C}$  and disregarding heat loss by radiation, obtain an expression for the variation of temperature in the base plate, and evaluate the temperatures at the inner and the outer surfaces.

**SOLUTION**

The base plate of an iron is considered. The variation of temperature in the plate and the surface temperatures are to be determined.

**Assumptions**

- 1 Heat transfer is steady since there is no change with time.
- 2 Heat transfer is one-dimensional since the surface area of the base plate is large relative to its thickness, and the thermal conditions on both sides are uniform.
- 3 Thermal conductivity is constant.
- 4 There is no heat generation in the medium.
- 5 Heat transfer by radiation is negligible.
- 6 The upper part of the iron is well insulated so that the entire heat generated in the resistance wires is transferred to the base plate through its inner surface.

**Properties**

The thermal conductivity is given to be  $k = 15 \text{ W/m} \cdot ^\circ\text{C}$ .

Analysis The inner surface of the base plate is subjected to uniform heat flux at a rate of

$$q_0 = \frac{Q_0}{A_{\text{base}}} = \frac{1200}{0.03} = 40,000 \text{ W/m}^2$$

The outer side of the plate is subjected to the convection condition. Taking the direction normal to the surface of the wall as the x-direction with its origin on the inner surface, the differential equation for this problem can be expressed as fig

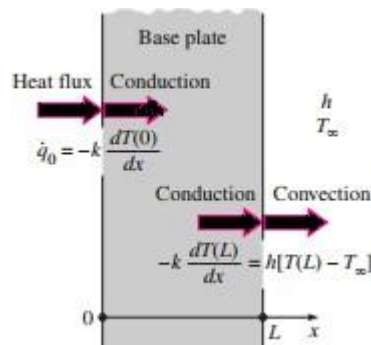

$$\frac{d^2 T}{dx^2} = 0$$

With the boundary conditions

$$-k \frac{dT(0)}{dx} = q_0 = 40000 \text{ W/m}^2$$

$$-k \frac{dT(L)}{dx} = h[T(L) - T_\infty]$$

The general solution of the differential equation is again obtained by two successive integrations to be

$$\frac{dT}{dx} = C_1$$

And

$$T(x) = C_1 x + C_2 \text{-----(1)}$$

Where  $C_1$  and  $C_2$  are arbitrary constants. Applying the first boundary condition,

$$-k \frac{dT(0)}{dx} = q_0 \longrightarrow -k C_1 = q_0 \longrightarrow C_1 = -\frac{q_0}{k}$$

$$-k \frac{dT(L)}{dx} = h[T(L) - T_\infty] \longrightarrow -k C_1 = h[(C_1 L + C_2) - T_\infty]$$

Substituting  $C_1 = -\frac{q_0}{k}$  and solving for  $C_2$  We obtain

$$C_2 = T_\infty + \frac{q_0}{h} + \frac{q_0}{k} L$$

Now substituting  $C_1$  and  $C_2$  into the general solution (1) gives

$$T(x) = T_\infty + q_0 \left( \frac{L-x}{k} + \frac{1}{h} \right) \text{-----(2)}$$

Which is the solution for the variation of the temperature in the plate. The temperatures at the inner and outer surfaces of the plate are determined by substituting  $x=0$  and  $x=L$ , respectively, into the relation (2)

$$\begin{aligned} T(0) &= T_\infty + q_0 \left( \frac{L}{k} + \frac{1}{h} \right) \\ &= 20^\circ \text{C} + (40000 \text{ W/m}^2) \left( \frac{0.005 \text{ m}}{15} + \frac{1}{80} \right) = 533^\circ \text{C} \end{aligned}$$

And

$$T(L) = T_\infty + q_0 \left( 0 + \frac{1}{h} \right) = 20^\circ \text{C} + \frac{40000}{80} = 520^\circ \text{C}$$

Discussion Note that the temperature of the inner surface of the base plate will be  $13^\circ \text{C}$  higher than the temperature of the outer surface when steady operating conditions are reached. Also note that this heat transfer analysis enables us to calculate the temperatures of surfaces that we cannot even reach. This example demonstrates how the heat flux and convection boundary conditions are applied to heat transfer problems.

**2. A person is found dead at 5 PM in a room whose temperature is  $20^\circ \text{C}$ . The temperature of the body is measured to be  $25^\circ \text{C}$  when found, and the heat transfer coefficient is estimated to be  $h = 8 \text{ W/m}^2 \cdot ^\circ \text{C}$ . Modeling the body as a 30-cm-diameter, 1.70-m-long cylinder, estimate the time of death of that person**

**SOLUTION** A body is found while still warm. The time of death is to be estimated.

**Assumptions** **1** The body can be modeled as a 30-cm-diameter, 1.70-m-long cylinder. **2** The thermal properties of the body and the heat transfer coefficient are constant. **3** The radiation effects are negligible. **4** The person was healthy(!) when he or she died with a body temperature of  $37^\circ \text{C}$ .

**Properties** The average human body is 72 percent water by mass, and thus we can assume the body to have the properties of water at the average temperature of  $(37 + 25)/2 = 31^\circ \text{C}$ ;  $k = 0.617 \text{ W/m} \cdot ^\circ \text{C}$ ,  $\rho = 996 \text{ kg/m}^3$ , and  $C_p = 4178 \text{ J/kg} \cdot ^\circ \text{C}$

**Analysis** The characteristic length of the body is

$$L_c = \frac{V}{A_s} = \frac{\pi r_0^2 L}{2\pi r_0 L + 2\pi r_0^2} = \frac{\pi (0.15)^2 (1.7)}{2\pi(0.15)(1.7) + 2\pi(0.15)^2} = 0.0689$$

Then the biot number becomes

$$B_i = \frac{hL_c}{k} = \frac{8 \times 0.0689}{0.617} = 0.89 > 0.1$$

Therefore lumped system analysis is not applicable. However, we can still use it to get a rough estimate of the time of death.

$$\frac{T(t) - T_\infty}{T_i - T_\infty} = e^{-bt} \text{-----(1)}$$

The exponent b in this case is

$$b = \frac{hA_s}{\rho C_p V} = \frac{h}{\rho C_p L_c} = \frac{8}{996 \times 4178 \times 0.0689} = 2.79 \times 10^{-5}$$

now substitute these values into equation (1)

$$\frac{25 - 20}{37 - 20} = e^{-2.79 \times 10^{-5} t}$$

$t = 43860 \text{ s} = 12.2 \text{ h}$
--

The person died about 12 h before the body was found and thus the time of death is 5 AM.

# UNIT 2

## UNIT: II - CONVECTION

### **1. Define critical Reynolds number. What is its typical value for flow over a flat plate and flow through a pipe? (May 2013, Nov/Dec 16)**

The critical Reynolds number refers to the transition from laminar to turbulent flow.

The critical Reynolds number for flow over a flat plate is  $5 \times 10^5$ ; the critical Reynolds number for flow through a pipe is 4000.

### **2. How does or Distinguish laminar flow differ from turbulent flow? (May 2013 & May 2015)**

**Laminar flow:** Laminar flow is sometimes called stream line flow. In this type of flow, the fluid moves in layers and each fluid particle follows a smooth continuous path. The fluid particles in each layer remain in an orderly sequence without mixing with each other.

**Turbulent flow:** In addition to the laminar type of flow, a distinct irregular flow is frequently observed in nature. This type of flow is called turbulent flow. The path of any individual particle is zig-zag and irregular.

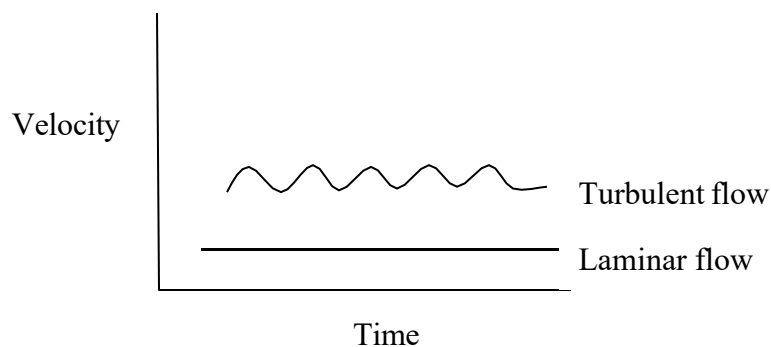

### **3. Differentiate viscous sub layer and buffer layer. (May 2014)**

In the turbulent boundary layer, a very thin layer next to the wall where viscous effect is dominant called the viscous sub layer. The velocity profile in this layer is very nearly linear and the flow is streamlined.

In the turbulent boundary layer, next to viscous sub layer, a layer called **buffer layer** in which turbulent effects are becoming significant, but the flow is still dominated by viscous effects.

**4. Define grashoff number and prandtl number. Write its significance. (May 2014 & Nov 2014 & Nov 2015-Reg 2008)(Nov 2015) (APR/MAY 2017)**

Grashoff number is defined as the ratio of product of inertia force and buoyancy force to the square of viscous force.

$$Gr = \frac{\text{Inertia Force} * \text{Buoyancy Force}}{(\text{Viscous Force})^2} \quad [\text{HMT Data Book, P.No 112}]$$

**Significance:** Grashoff number has a role in free convection similar to that played by Reynolds number in forced convection.

Prandtl number is the ratio of the momentum diffusivity of the thermal diffusivity.

$$Pr = \frac{\text{Momentum Diffusivity}}{\text{Thermal Diffusivity}} \quad [\text{HMT Data Book, P.No. 112}]$$

**Significance:** Prandtl number provides a measure of the relative effectiveness of the momentum and energy transport by diffusion.

**5. Define velocity boundary layer thickness. (May 2015)**

The region of the flow in which the effects of the viscous shearing forces caused by fluid viscosity are felt is called velocity boundary layer. The velocity boundary layer thickness,  $\delta$ , is defined as the distance from the surface at which velocity,  $u = 0.99V$

**6. Air at 27°C and 1 atmospheric flow over a flat plate at a speed of 2m/s. Calculate boundary layer thickness at a distance 40 cm from leading edge of plate. At 27°C viscosity (air) =  $1.85 * 10^{-5}$  kg/ms. (Nov 2012)**

**Given Data:**

$$T = 27^\circ\text{C} = 27 + 273 = 300\text{K}$$

$$P = 1 \text{ atm} = 1 \text{ bar} = 1.01325 * 10^5 \text{ N/m}^2$$

$$U = 2 \text{ m/s}$$

$$\mu = 1.85 * 10^{-5} \text{ kg/ms. (At } 27^\circ\text{C)}$$

$$R = 287 \text{ (Gas constant)}$$

**To Find:**  $\delta$  at  $X = 40 \text{ cm} = 0.4 \text{ m}$

**Solution:**

**Step: 1** Density  $\rho = \frac{P}{RT}$   
 $= \frac{1.01325 * 10^5}{(287 * 300)}$

$$= 1.177 \text{ Kg/m}^3$$

(Note: If Surface temperature ( $T_w$ ) is given, then properties to be taken for  $T_f$  Value.)

**Step: 2** Reynolds Number  $Re = \rho UX / \mu$  [HMT Data Book, P.No. 112]

$$= \frac{1.177 * 2 * 0.4}{1.85 * 10^{-5}}$$

$$= 55160. \text{ (Re} < 5 * 10^5, \text{ flow is laminar)}$$

**Step: 3** Boundary layer thickness  $\delta = 5 * X * (Re)^{-0.5}$

[HMT Data Book, P.No.113]

$$= 5 * 0.4 * (55160)^{-0.5}$$

$$= 0.0085 \text{ m}$$

$$\text{Boundary layer thickness } \delta \text{ at } X \text{ (0.4m)} = 0.0085 \text{ m}$$

**7. A square plate 40\*40 cm maintained at 400K is suspended vertically in atmospheric air at 300 K. Determine the boundary layer thickness at trailing edge of the plate. (Nov 2012)**

**Given Data:**

Length of horizontal plate  $X = 40 \text{ cm} = 0.4 \text{ m}$

Wide  $W = 40 \text{ cm} = 0.40 \text{ m}$

Plate temperature  $T_w = 400 \text{ K} = 127^\circ \text{C}$

Fluid temperature  $T_\alpha = 300 \text{ K} = 27^\circ \text{C}$

$\Delta T = (T_w - T_\alpha) = 400 - 300 = 100$

**To Find:**  $\delta$  at  $X = 40 \text{ cm} = 0.4 \text{ m}$

**Solution:**

$$\begin{aligned} \text{Step: 1 Film Temperature } (T_f) &= \frac{T_w + T_\alpha}{2} \\ &= \frac{127 + 27}{2} = 77^\circ \text{C} = 350 \text{ K} \end{aligned}$$

**Step: 2** Properties of air at  $77^\circ \text{C}$  (apprx  $75^\circ \text{C}$ )

[HMT Data Book, P.No.34]

$$\nu = 20.56 * 10^{-6} \text{ m}^2/\text{s}$$

$$\text{Pr} = 0.693$$

**Step: 3** Find  $\beta = 1 / T_f$  in K

$$= 1 / 350$$

$$= 2.857 * 10^{-3} \text{ K}^{-1}$$

**Step: 4** For free Convection (Note: As Velocity not given)

$$\text{Gr} = \frac{g * \beta * X^3 * \Delta T}{\nu^2} \quad [\text{HMT Data Book, P.No.135}]$$

$$= \frac{9.81 * 2.857 * 10^{-3} * (0.4)^3 * (400-300)}{(20.56 * 10^{-6})^2}$$

$$= 4.24 * 10^8$$

**Step: 5** Boundary layer thickness  $\delta = 3.93 * X * (\text{Pr})^{-0.5} * (0.952 + \text{Pr})^{0.25} * \text{Gr}^{-0.25}$

[HMT Data Book, P.No.135]

$$= 3.93 * 0.4 * (0.693)^{-0.5} * (0.952 + 0.693)^{0.25} * (4.24 * 10^8)^{-0.25}$$

$$= 0.0155 \text{ m}$$

Boundary layer thickness $\delta$ at X (0.4m) = 0.0155 m
--

## 8. Define the term thermal boundary layer thickness. (Nov 2013)

The thickness of the thermal boundary layer  $\delta_t$  at any location along the surface is defined as the distance from the surface at which the temperature difference equals to  $0.99(T_\alpha - T_s)$ , in general  $T = 0.99T_\alpha$

## 9. Why heat transfer coefficient for natural convection is much lesser than that for forced convection? (Nov 2013 & May 2016)

Heat transfer coefficient depends on the fluid velocity.

In natural convection, the fluid motion occurs by natural means such as buoyancy. Since the fluid velocity associated with natural convection is relatively low, the heat transfer coefficient encountered in natural convection is low.

The reason for higher heat transfer rates in forced convection is because the hot air surrounding the hot body is immediately removed by the flow of air around it. This is why forced convection heat transfer coefficient is greater than natural convection heat transfer coefficient.

**10. Name four dimensions used for dimensional analysis. (Nov 2014)**

1. Velocity
2. Density
3. Heat transfer coefficient
4. Thermal conductivity

**11. Mention the significance of boundary layer. (Nov 2015)**

Boundary layer is the layer of fluid in the immediate vicinity of a bounding surface where the effects of viscosity are significant.

**12. What is Dittus Boelter equation? When does it apply? (Nov 2015)**

Dittus-Boelter equation (for fully developed internal flow - turbulent flow) is an explicit function for calculating the Nusselt number. It is easy to solve but is less accurate when there is a large temperature difference across the fluid. It is tailored to smooth tubes, so use for rough tubes (most commercial applications) is cautioned.

The Dittus-Boelter equation is:

$$Nu_D = 0.023 Re_D^{0.8} Pr^n \quad [\text{HMT Data Book, P.No.126}]$$

**13. What is the difference between friction factor and friction coefficient? (May 2016)**

Friction factor, a dimensionless quantity used in the Darcy–Weisbach equation, for the description of friction losses in pipe flow as well as open-channel flow. Friction coefficient applied at the value of  $x$  ( $x=x$ -Local friction coefficient,  $x=L$  – Average friction coefficient)

**14. Differentiate free and forced convection. (May 2016) (Nov/Dec 16)**

Natural convection, or free convection, occurs due to temperature differences which affect the density, and thus relative buoyancy, of the fluid. Free convection is governed by Grashoff number and Prandtl number.

**Example:** Rise of smoke from a fire.

In forced convection, fluid movement results from external forces such as a fan or pump. Forced convection is typically used to increase the rate of heat exchange. It is governed by the value of the Reynolds number.

**Example:** Cooling of IC engines with fan in a radiator.

**15. Differentiate hydrodynamic and thermal boundary layer. (May 2016)**

The hydrodynamic boundary layer is a region of a fluid flow, near a solid surface, where the flow patterns (velocity) are directly influenced by viscous drag from the surface wall. The velocity of the fluid is less than 99% of free stream velocity.

The thermal boundary layer is a region of a fluid flow, near a solid surface, where the fluid temperatures are directly influenced by heating or cooling from the surface wall. The temperature of the fluid is less than 99% of free stream temperature.

**16. What are the difference between natural convection and forced convection? ( Nov/Dec 16)**

Natural convection is a mechanism of heat transportation in which the fluid motion is not generated by an external source.

Forced convection is a mechanism, or type of heat transport in which fluid motion is generated by an external source (like a pump, fan, suction device, etc.)

**1. Air at 25°C at the atmospheric pressure is flowing over a flat plat at 3m/s. If the plate is 1m wide and the temperature  $T_w = 75^\circ\text{C}$ . Calculate the following at a location of 1m from leading edge.**

- a) Hydrodynamic boundary layer thickness,
- b) Local friction coefficient,
- c) Thermal heat transfer coefficient,
- d) Local heat transfer coefficient.

**Given Data:**

Fluid temperature,  $T_\alpha = 25^\circ\text{C}$

Velocity,  $U = 3\text{m/s}$

Wide,  $W = 1\text{m}$

Plate surface temperature,  $T_w = 75^\circ\text{C}$

Distance,  $x = 1\text{m}$

**To Find:**  $\delta_{hx}$ ,  $C_{fx}$ ,  $\delta_{Tx}$ ,  $h_x$ ,

**Solution:**

[From HMT Data Book, P.No.113]

$$\text{Film temperature, } T_f = \frac{T_w + T_\alpha}{2}$$
$$= \frac{75 + 25}{2} = 323\text{K}$$

$$T_f = 50^\circ\text{C}$$

Properties of air at 50°C:

[From HMT Data Book, P.No.34]

Density,  $\rho = 1.093\text{kg/m}^3$

Kinematic viscosity,  $\nu = 17.95 \times 10^{-6} \text{m}^2/\text{s}$

Prandtl number  $Pr = 0.698$

Thermal conductivity,  $k = 0.02826 \text{W/mk}$

Reynolds number,  $Re = UL/\nu$

[From HMT Data Book, P.No.112]

$$[\because x = L = 1\text{m}]$$

$$\frac{3 \times 1}{17.95 \times 10^{-6}} = 1.67 \times 10^5$$

$$Re = 1.67 \times 10^5 < 5 \times 10^5$$

Since  $Re < 5 \times 10^5$  flow is laminar.

For the plate, laminar flow.

[From HMT Data Book, P.No.113]

1. Hydrodynamic boundary layer thickness,

$$\delta_{hx} = 5 \sqrt{x} Re^{-0.5}$$
$$= 5 \sqrt{x} (1.67 \times 10^5)^{-0.5}$$

$$\delta_{hx} = 0.0122\text{m}$$

2. Local friction coefficient,

[From HMT Data Book, P.No.113]

$$C_{fx} = 0.664 Re^{-0.5}$$
$$= 0.664 (1.67 \times 10^5)^{-0.5}$$

$$C_{fx} = 1.62 \times 10^{-3}$$

3. Thermal heat transfer coefficient,

[From HMT Data Book, P.No.113]

$$\begin{aligned}\delta_{Tx} &= \delta_{hx} * (Pr)^{-0.333} \\ &= 0.0122 * (0.698)^{-0.333}\end{aligned}$$

$\delta_{Tx} = 0.01375$
-------------------------

4. Local heat transfer coefficient,  $h_x$

[From HMT Data Book, P.No.113]

$$\begin{aligned}\text{Local nusselt number } Nu_x &= 0.332 Re^{0.5} (Pr)^{0.333} \\ &= 0.332 (1.67 * 10^5)^{0.5} (0.698)^{0.333}\end{aligned}$$

$$Nu_x = 120.415$$

[From HMT Data Book, P.No.112]

$$Nu_x = \frac{h_x * L}{k}$$

$$120.415 = \frac{h_x * 1}{0.02826}$$

[∴  $x=L=1m$ ]

Local heat transfer coefficient, $h_x = 3.4W/m^2K$
--

**Result:**

- a)  $\delta_{hx} = 0.0122m$
- b)  $C_{fx} = 1.62 * 10^{-3}$
- c)  $\delta_{Tx} = 0.01375$
- d)  $h_x = 3.4W/m^2K$

**2. Air at 290°C flows over a flat plate at a velocity of 6 m/s. The plate is 1m long and 0.5 m wide. The pressure of the air is 6 KN/m<sup>2</sup>. If the plate is maintained at a temperature of 70°C, estimate the rate of heat removed from the plate.**

**Given:**

Fluid temperature  $T_{\infty} = 290^{\circ}C$

Velocity  $U = 6 m/s$ .

Length  $L = 1 m$

Wide  $W = 0.5 m$

Pressure of air  $P = 6 KN/m^2 = 6 \times 10^3 N/m^2$

Plate surface temperature  $T_w = 70^\circ\text{C}$

**To find:**

Heat removed from the plate

**Solution:**

[From HMT Data Book, P.No.113]

$$\begin{aligned}\text{Film temperature } T_f &= \frac{T_w + T_\infty}{2} \\ T_f &= \frac{70 + 290}{2} \\ T_f &= 180^\circ\text{C}\end{aligned}$$

Properties of air at  $180^\circ\text{C}$  (At atmospheric pressure)

[From HMT Data Book, P.No.34]

$$\begin{aligned}\rho &= 0.799 \text{ Kg/m}^3 \\ \nu &= 32.49 \times 10^{-6} \text{ m}^2/\text{s} \\ \text{Pr} &= 0.681 \\ K &= 37.80 \times 10^{-3} \text{ W/mK}\end{aligned}$$

**Note:** Pressure other than atmospheric pressure is given, so kinematic viscosity will vary with pressure. Pr, K,  $C_p$  are same for all pressures.

$$\text{Kinematic viscosity } \nu = \nu_{\text{atm}} \frac{P_{\text{atm}}}{P_{\text{given}}}$$

[ $\because 1 \text{ bar} = 1 \times 10^5 \text{ N/m}^2$ ]

$$\begin{aligned}\nu &= 32.49 \times 10^{-6} \times \frac{1 \times 10^5}{6 \times 10^3} \\ \text{Kinematic viscosity } \nu &= 5.145 \times 10^{-4} \text{ m}^2/\text{s}\end{aligned}$$

[From HMT Data Book, P.No.112]

$$\begin{aligned}\text{Reynolds number } \text{Re} &= \frac{UL}{\nu} \\ &= \frac{6 \times 1}{5.145 \times 10^{-4}}\end{aligned}$$

$$\text{Re} = 1.10 \times 10^4 - 5 \times 10^5$$

Since  $\text{Re} < 5 \times 10^5$ , flow is laminar

For plate, laminar flow,  $UL \nu$

[From HMT Data Book, P.No.113]

$$\begin{aligned}\text{Local nusselt number } \text{Nu}_x &= 0.332 \text{ Re}^{0.5} (\text{Pr})^{0.333} \\ &= 0.332 (1.10 \times 10^4)^{0.5} (0.681)^{0.333}\end{aligned}$$

$$Nu_x=30.63$$

[From HMT Data Book, P.No.112]

$$Nu_x = \frac{h_x L}{K}$$

$$30.63 = \frac{h_x \times 1}{37.80 \times 10^{-3}} \quad [L = 1 \text{ m}]$$

Local heat transfer coefficient  $h_x = 1.15 \text{ W/m}^2\text{K}$

Average heat transfer coefficient  $h = 2 \times h_x$

$$h = 2 \times 1.15$$

$$h = 2.31 \text{ W/m}^2\text{K}$$

Heat transferred  $Q = h A (T_\alpha - T_w)$

$$= 2.13 \times (1 \times 0.5) \times (563 - 343)$$

$$Q = 254.1 \text{ W}$$

Heat transfer from both side of the plate  $= 2 \times 254.1$

$$= 508.2 \text{ W.}$$

**Result:** Heat transfer from both side of the plate = 508.2 W

**3. A large vertical plate 4 m height is maintained at 606°C and exposed to atmospheric air at 106°C. Calculate the heat transfer is the plate is 10 m wide.**

**Given :**

Vertical plate length (or) Height,  $L = 4 \text{ m}$

Wall temperature,  $T_w = 606^\circ\text{C}$

Air temperature,  $T_\infty = 106^\circ\text{C}$

Wide,  $W = 10 \text{ m}$

**To find:**

a) Heat transfer, (Q)

**Solution:**

[From HMT Data Book, P.No.113]

$$\begin{aligned} \text{Film temperature } T_f &= \frac{T_w + T_\alpha}{2} \\ &= \frac{606 + 106}{2} \\ T_f &= 356^\circ\text{C} \end{aligned}$$

[From HMT Data Book, P.No.34 ]

Properties of air at  $356^{\circ}\text{C} = 350^{\circ}\text{C}$

Density,  $\rho = 0.566\text{kg/m}^3$

Kinematic viscosity,  $\nu = 55.46 \times 10^{-6} \text{m}^2/\text{s}$

Prandtl number  $\text{Pr} = 0.698$

Thermal conductivity,  $k = 49.08 \times 10^{-3} \text{W/mk}$

Coefficient of thermal expansion  $\beta = \frac{1}{T_f \text{ in K}}$

$$= \frac{1}{356 + 273} = \frac{1}{629}$$
$$\beta = 1.58 \times 10^{-3} \text{K}^{-1}$$

$$\text{Grashof number } Gr = \frac{g \times \beta \times L^3 \times \Delta T}{\nu^2}$$
$$\Rightarrow Gr = \frac{9.81 \times 2.4 \times 10^{-3} \times (4)^3 \times (606 - 106)}{(55.46 \times 10^{-6})^2}$$
$$\Rightarrow Gr = 1.61 \times 10^{11}$$

$$Gr \text{ Pr} = 1.61 \times 10^{11} \times 0.676$$

$$Gr \text{ Pr} = 1.08 \times 10^{11}$$

Since  $Gr \text{ Pr} > 10^9$ , flow is turbulent For turbulent flow,

$$\text{Nusselt number } Nu = 0.10 [Gr \text{ Pr}]^{0.333}$$

$$\Rightarrow Nu = 0.10 [1.08 \times 10^{11}]^{0.333} Nu = 471.20$$

[From HMT Data Book, P.No.112]

$$\text{Nusselt number } Nu = \frac{hL}{K}$$

$$\Rightarrow 472.20 = \frac{h \times 4}{49.08 \times 10^{-3}}$$

Heat transfer coefficient  $h = 5.78 \text{ W/m}^2\text{K}$

Heat transfer  $Q = h A \Delta T$

$$= h \times W \times L \times (T_w - T_{\infty})$$

$$= 5.78 \times 10 \times 4 \times (606 - 106)$$

$$Q = 115600 \text{ W}$$

$$Q = 115.6 \times 10^3 \text{ W}$$

**Result:**

Heat transfer  $Q = 115.6 \times 10^3 \text{ W}$

**4. A thin 100 cm long and 10 cm wide horizontal plate is maintained at a uniform temperature of 150°C in a large tank full of water at 75°C. Estimate the rate of heat to be supplied to the plate to maintain constant plate temperature as heat is dissipated from either side of plate.**

**Given :**

Length of horizontal plate,  $L = 100 \text{ cm} = 1 \text{ m}$

Wide,  $W = 10 \text{ cm} = 0.10 \text{ m}$

Plate temperature,  $T_w = 150^\circ\text{C}$

Fluid temperature,  $T_\infty = 75^\circ\text{C}$

**To find:**

a) Heat loss ( $Q$ ) from either side of plate

**Solution:**

$$\text{Film temperature, } T_f = \frac{T_w + T_\infty}{2} \quad [\text{From HMT Data Book, P.No.113}]$$
$$= \frac{150 + 75}{2} = 323 \text{ K}$$

$$T_f = 112.5^\circ\text{C}$$

Properties of water at 112.5°C

$\rho = 951 \text{ Kg/m}^3$

$\nu = 0.264 \times 10^{-6} \text{ m}^2/\text{s}$

$Pr = 1.55$

$K = 683 \times 10^{-3} \text{ W/mK}$

$$\text{Coefficient of thermal expansion } \beta = \frac{1}{T_f \text{ in K}} = \frac{1}{112.5 + 273} = 2.59 \times 10^{-3} \text{ K}^{-1}$$

$$\text{Grashof Number } Gr = \frac{g \times \beta \times L^3 \times \Delta T}{\nu^2}$$

For horizontal plate,

$$\text{Characteristic length } L_c = \frac{W}{2} = \frac{0.10}{2}$$

$$L_c = 0.05 \text{ m}$$

$$Gr = \frac{9.81 \times 2.59 \times 10^{-3} \times (0.05)^3 \times (150 - 75)}{(0.264 \times 10^{-6})^2}$$

$$Gr = 3.41 \times 10^9$$

$$GrPr = 3.14 \times 10^9 \times 1.55$$

$$GrPr = 5.29 \times 10^9$$

Gr Pr value is in between  $8 \times 10^6$  and  $10^{11}$

i.e.,  $8 \times 10^6 < GrPr < 10^{11}$

For horizontal plate, upper surface heated:

$$\text{Nusselt number } Nu = 0.15 (GrPr)^{0.333}$$

[From HMT Data Book, P.No.114 ]

$$Nu = 0.15 (5.29 \times 10^9)^{0.333}$$

$$Nu = 259.41$$

$$\text{Nusselt number } Nu = \frac{h_u L_c}{K}$$

$$259.41 = \frac{h_u \times 0.05}{683 \times 10^{-3}}$$

$$h_u = 3543.6 \text{ W/m}^2\text{K}$$

Upper surface heated, heat transfer coefficient  $h_u = 3543.6 \text{ W/m}^2\text{K}$

For horizontal plate, lower surface heated:

$$\text{Nusselt number } Nu = 0.27 [GrPr]^{0.25}$$

$$Nu = 0.27 [5.29 \times 10^9]^{0.25}$$

$$Nu = 72.8$$

[From HMT Data Book, P.No.113]

$$\text{Nusselt number } Nu = \frac{h_l L_c}{K}$$

$$72.8 = \frac{h_l L_c}{K}$$

$$72.8 = \frac{h_l \times 0.05}{683 \times 10^{-3}}$$

$$h_1 = 994.6 \text{ W/m}^2\text{K}$$

Lower surface heated, heat transfer coefficient  $h_1 = 994.6 \text{ W/m}^2\text{K}$

$$\begin{aligned} \text{Total heat transfer } Q &= (h_u + h_1) \times A \times \Delta T \\ &= (h_u + h_1) \times W \times L \times (T_w - T_\infty) \\ &= (3543.6 + 994.6) \times 0.10 \times (150 - 75) \end{aligned}$$

$Q = 34036.5 \text{ W}$
-------------------------

**Result:**

$$\text{Total heat transfer } Q = 34036.5 \text{ W}$$

## 5. Explain in detail about the boundary layer concept.

The concept of a boundary layer as proposed by Prandtl forms the starting point for the simplification of the equation of motion and energy.

When a real i.e., viscous fluid, flows along a stationary solid boundary, a layer of fluid which comes in contact with the boundary surface and undergoes retardation. This retarded layer further causes retardation for the adjacent layer of the fluid. So a small region is developed in the immediate vicinity of the boundary surface in which the velocity of the flowing fluid increases rapidly from zero at the boundary surface and approaches the velocity of the main stream.

### Types of boundary layer

1. **Velocity boundary layer (or) hydrodynamic boundary layer**
2. **Thermal boundary layer**

### Velocity boundary layer (or) hydrodynamic boundary layer

In the velocity boundary layer, the velocity of the fluid is less than 99% of the free stream velocity.

The fluid approaches the plate in the x-direction with uniform velocity  $u_\infty$ . The fluid particles in the fluid layer adjacent to the surface get zero velocity. This motionless layer acts to retard the motion of particles in the adjoining fluid layer as a result of friction between the particles of these two adjoining fluid layers at two different velocities. This fluid layer then acts to retard the motion of particles of the next fluid layer and so on, until a distance  $y = \delta$  from the surface is reached, where

these effects become negligible and the fluid velocity  $u$  reaches the free stream velocity  $u_\infty$  as a result of frictional effects between the fluid layers.

### **Thermal boundary Layer:**

In the Thermal boundary layer, temperature of the fluid is less than 99% of free stream temperature.

If the fluid flowing on a surface has a different temperature than the surface, the thermal boundary layer developed is similar to the velocity boundary layer. Consider a fluid at a temperature  $T_\infty$  flows over a surface at a constant temperature  $T_s$ . The fluid particles in adjacent layer to the plate get the same temperature that of surface. The particles exchange heat energy with particles in adjoining fluid layers and so on. As a result, the temperature gradients are developed in the fluid layers and a temperature profile is developed in the fluid flow, which ranges from  $T_s$  at the surface to fluid temperature  $T_\infty$  sufficiently far from the surface in  $y$  direction.

### **Velocity boundary layer on a flat plate:**

It is most essential to distinguish between laminar and turbulent boundary layers. Initially, the boundary layer development is laminar as shown in figure for the flow over a flat plate. Depending upon the flow field and fluid properties, at some critical distance from the leading edge small disturbances in the flow begin to get amplified, a transition process takes place and the flow becomes turbulent. In laminar boundary layer, the fluid motion is highly ordered whereas the motion in the turbulent boundary layer is highly irregular with the fluid moving to and from in all directions. Due to fluid mixing resulting from these macroscopic motions, the turbulent boundary layer is thicker and the velocity profile in turbulent boundary layer is flatter than that in laminar flow.

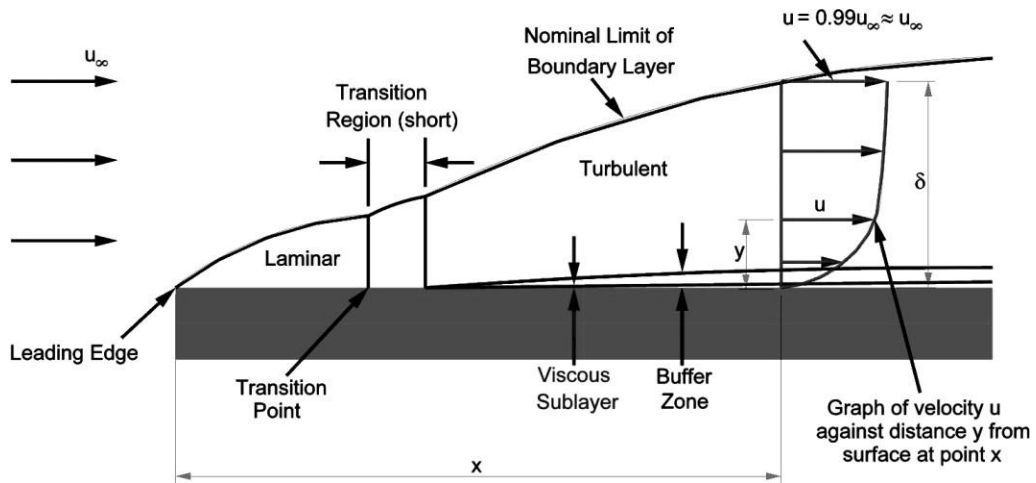

### Velocity boundary layer on a tube:

#### Laminar Boundary Layer Flow

The laminar boundary is a very smooth flow, while the turbulent boundary layer contains swirls or "eddies." The laminar flow creates less skin friction drag than the turbulent flow, but is less stable. Boundary layer flow over a wing surface begins as a smooth laminar flow. As the flow continues back from the leading edge, the laminar boundary layer increases in thickness.

#### Turbulent Boundary Layer Flow

At some distance back from the leading edge, the smooth laminar flow breaks down and transitions to a turbulent flow. From a drag standpoint, it is advisable to have the transition from laminar to turbulent flow as far aft on the wing as possible, or have a large amount of the wing surface within the laminar portion of the boundary layer. The low energy laminar flow, however, tends to break down more suddenly than the turbulent layer.

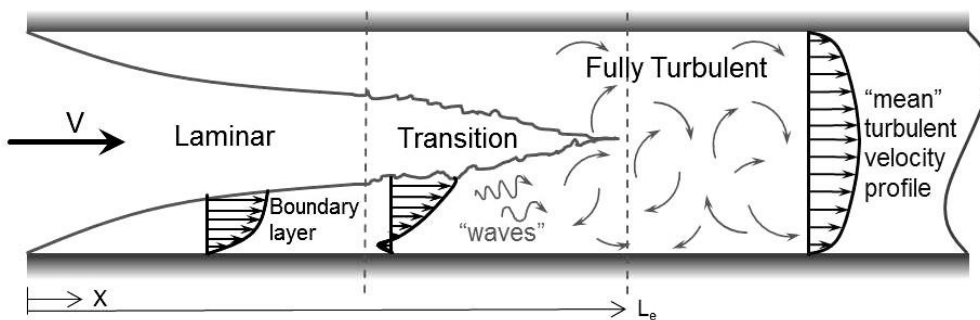

### Thermal boundary Layer on a flat plate:

Consider a fluid of uniform temperature  $T_\alpha$  approaching a flat plate of constant temperature  $T_s$  in the direction parallel to the plate. At the solid/liquid interface

the fluid temperature is  $T_s$  since the local fluid particles achieve thermal equilibrium at the interface. The fluid temperature  $T$  in the region near the plate is affected by the plate, varying from  $T_s$  at the surface to  $T_\infty$  in the main stream. This region is called the thermal boundary layer.

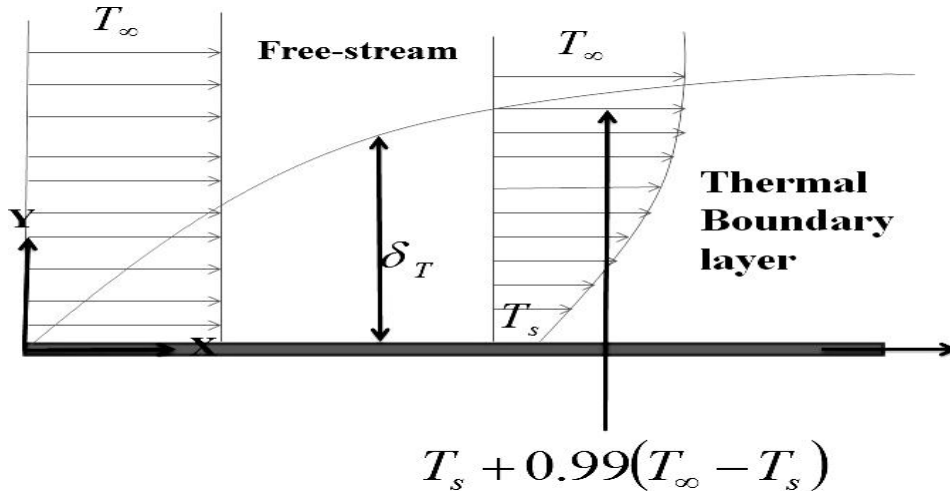

### Velocity and Temperature boundary layer (Profile) for a vertical plate

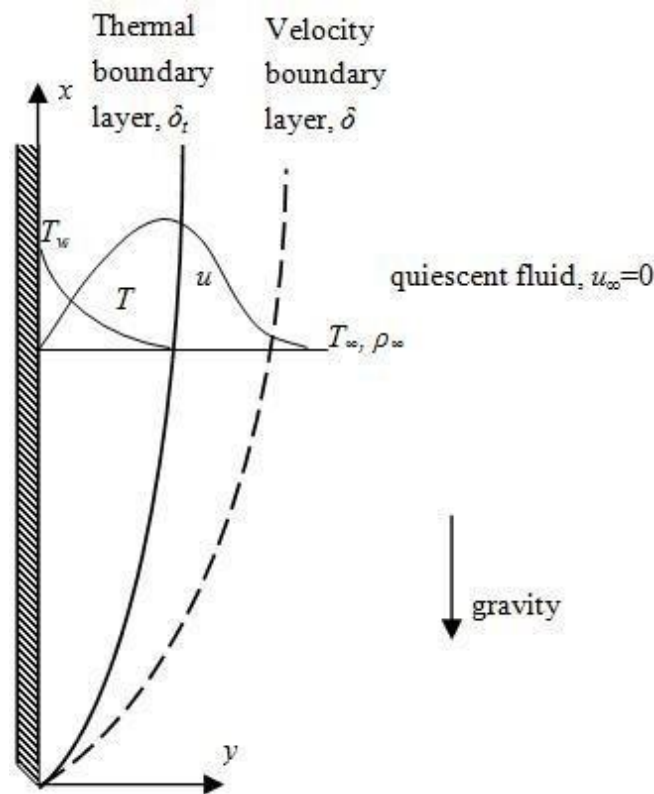

6. In a long annulus (3.125 cm ID and 5 cm OD) the air is heated by maintaining the temperature of the outer surface of inner tube at 50°C. The air enters at 16°C and leaves at 32°C. Its flow rate is 30 m/s. Estimate the heat transfer coefficient between air and the inner tube.

**Given :** Inner diameter  $D_i = 3.125 \text{ cm} = 0.03125 \text{ m}$

Outer diameter  $D_o = 5 \text{ cm} = 0.05 \text{ m}$

Tube wall temperature  $T_w = 50^\circ\text{C}$

Inner temperature of air  $T_{mi} = 16^\circ\text{C}$

Outer temperature of air  $t_{mo} = 32^\circ\text{C}$

Flow rate  $U = 30 \text{ m/s}$

**To find:** Heat transfer coefficient (h)

**Solution:**

$$\begin{aligned} \text{Step 1. Mean temperature } T_m &= \frac{T_{m1} + T_{m2}}{2} \\ &= \frac{16 + 32}{2} \end{aligned}$$

$$T_m = 24^\circ\text{C}$$

Properties of air at  $24^\circ\text{C}$

[From HMT Data book page no. 34]

$$\rho = 1.185 \text{ Kg/m}^3$$

$$\nu = 15.53 \times 10^{-6} \text{ m}^2/\text{s}$$

$$\text{Pr} = 0.702$$

$$k = 0.02634 \text{ W/mK}$$

Step 2. Hydraulic or Equivalent diameter

$$\begin{aligned} D_h &= \frac{4A}{P} = \frac{4 \times \frac{\pi}{4} [D_o^2 - D_i^2]}{\pi [D_o + D_i]} \\ &= \frac{[D_o + D_i][D_o - D_i]}{[D_o + D_i]} \\ &= D_o - D_i \\ &= 0.05 - 0.03125 \end{aligned}$$

$$D_h = 0.01875 \text{ m}$$

$$\begin{aligned} \text{Step 3. Reynolds number, } Re &= \frac{UD_h}{\nu} \\ &= \frac{30 \times 0.01875}{15.53 \times 10^{-6}} \end{aligned}$$

$$Re = 36.2 \times 10^3$$

Since  $Re > 2300$ , flow is turbulent.

For turbulent flow, general equation is ( $Re > 10000$ ).

$$Nu = 0.023 (Re)^{0.8} (Pr)^n$$

[From HMT Data book, Page No. 126]

This is heating process. So  $n = 0.4$ .

$$[T_{mo} > T_{mi}]$$

$$\text{Step 4. } Nu = 0.023 \times (36.2 \times 10^3)^{0.8} (0.702)^{0.4}$$

$$Nu = 88.59$$

$$\text{Step 5. } Nu = \frac{hD_h}{k}$$

$$88.59 = \frac{h \times 0.01875}{26.34 \times 10^{-3}}$$

$$h = 124.4 \text{ W/m}^2\text{K}$$

Heat transfer coefficient,  $h = 124.4 \text{ W/m}^2\text{K}$

**7. In a surface condenser, water flows through staggered tubes while the air is passed in cross flow over the tubes. The temperature and velocity of air are  $30^\circ\text{C}$  and  $8 \text{ m/s}$  respectively. The longitudinal and transverse pitches are  $22 \text{ mm}$  and  $20 \text{ mm}$  respectively. The tube outside diameter is  $18 \text{ mm}$  and tube surface temperature is  $90^\circ\text{C}$ . Calculate the heat transfer coefficient.**

**Given:**

Fluid temperature,  $T_\infty = 30^\circ\text{C}$

Velocity,  $U = 8 \text{ m/s}$

Longitudinal pitch,  $S_l = 22 \text{ mm} = 0.022 \text{ m}$

Transverse pitch,  $S_t = 20 \text{ mm} = 0.020 \text{ m}$

Diameter,  $D = 18 \text{ mm} = 0.018 \text{ m}$

Tube surface temperature,  $T_w = 90^\circ\text{C}$

**To find:**

Step 1. Heat transfer coefficient.

**Solution:**

We know that,

$$\text{Film temperature, } T_f = \frac{T_w + T_\infty}{2}$$

$$= \frac{90 + 30}{2}$$

$$T_f = 60^\circ\text{C}$$

Properties of air at  $60^\circ\text{C}$

[From HMT data book, Page No. 34]

$$\nu = 18.97 \times 10^{-6} \text{ m}^2/\text{s}$$

$$\text{Pr} = 0.696$$

$$K = 0.02896 \text{ W/mK}$$

$$\text{Step 2. Maximum velocity, } U_{\max} = U \times \frac{S_t}{S_t - D}$$

$$U_{\max} = 8 \times \frac{0.020}{0.020 - 0.018}$$

$$U_{\max} = 80 \text{ m/s}$$

$$\text{Step 3. Reynolds Number, } \text{Re} = \frac{U_{\max} \times D}{\nu}$$

$$= \frac{80 \times 0.018}{18.97 \times 10^{-6}}$$

$$\text{Re} = 7.5 \times 10^4$$

$$\frac{S_t}{D} = \frac{0.020}{0.018} = 1.11$$

$$\boxed{\frac{S_t}{D} = 1.11}$$

$$\frac{S_l}{D} = \frac{0.022}{0.018} = 1.22$$

$$\boxed{\frac{S_l}{D} = 1.22}$$

$\frac{S_t}{D} = 1.11$ ,  $\frac{S_l}{D} = 1.22$ , corresponding C, n values are 0.518 and 0.556 respectively.

[From HMT data book, page No. 123]

$$C = 0.518$$

$$n = 0.556$$

Step 4. Nusselt Number,  $Nu = 1.13 (Pr)^{0.333} [C (Re)^n]$

[From HMT data book, Page No. 123 ]

$$Nu = 1.13 \times (0.696)^{0.333} \times [0.518 \times (7.5 \times 10^4)^{0.556}]$$

$$Nu = 266.3$$

Step 5. Nusselt Number,  $Nu = \frac{hD}{k}$

$$266.3 = \frac{h \times 0.018}{28.96 \times 10^{-3}}$$

$$\text{Heat transfer coefficient, } h = 428.6 \text{ W/m}^2\text{K}$$

**8. A thin 100 cm long and 10 cm wide horizontal plate is maintained at a uniform temperature of 150°C in a large tank full of water at 75°C. Estimate the rate of heat to be supplied to the plate to maintain constant plate temperature as heat is dissipated from either side of plate.**

**Given:**

Length of horizontal plate  $L = 100 \text{ cm} = 1 \text{ m}$

Wide  $W = 10 \text{ cm} = 0.10 \text{ m}$

Plate temperature  $T_w = 150^\circ\text{C}$

Fluid temperature  $T_\infty = 75^\circ\text{C}$

**To find:** Heat loss (Q) from either side of plate:

**Solution:**

$$\begin{aligned} \text{Step 1. Film temperature, } T_f &= \frac{T_w + T_\infty}{2} \\ &= \frac{150 + 75}{2} \end{aligned}$$

$$T_f = 112.5^\circ\text{C}$$

Properties of water at 112.5°C:

[From HMT data book, Page No. 22]

$$\rho = 951 \text{ Kg/m}^3$$

$$\nu = 0.264 \times 10^{-6} \text{ m}^2/\text{s}$$

$$Pr = 1.55$$

$$k = 0.683 \text{ W/mK}$$

$$\beta_{(\text{for water})} = 0.8225 \times 10^{-3} \text{ K}^{-1}$$

[From HMT data book, Page No. 30]

$$\text{Step 2. Grashof Number, } Gr = \frac{g \times \beta \times L_c^3 \times \Delta T}{\nu^2}$$

For horizontal plate,

$$\text{Characteristic length, } L_c = \frac{W}{2} = \frac{0.10}{2}$$

$$L_c = 0.05 \text{ m}$$

$$Gr = \frac{9.81 \times 0.8225 \times 10^{-3} \times (0.05)^3 \times (150 - 75)}{(0.264 \times 10^{-6})^2}$$

$$Gr = 1.0853 \times 10^9$$

$$GrPr = 1.0853 \times 10^9 \times 1.55$$

$$GrPr = 1.682 \times 10^9$$

GrPr value is in between  $8 \times 10^6$  and  $10^{11}$

i.e.,  $8 \times 10^6 < GrPr < 10^{11}$

For horizontal plate, upper surface heated:

$$\text{Step 3. Nusselt Number, } Nu = 0.15 (GrPr)^{0.333}$$

[From HMT data book, Page No. 136]

$$Nu = 0.15 [1.682 \times 10^9]^{0.333}$$

$$Nu = 177.13$$

$$\text{Step 4. Nusselt Number, } Nu = \frac{h_u L_c}{k}$$

$$177.13 = \frac{h_u \times 0.05}{0.683}$$

$$h_u = 2419.7 \text{ W/m}^2\text{K}$$

Upper surface heated, heat transfer coefficient

$$h_u = 2419.7 \text{ W/m}^2\text{K}$$

For horizontal plate, lower surface heated:

$$\text{Step 5. Nusselt Number } Nu = 0.27 [GrPr]^{0.25}$$

[From HMT data book, Page No. 136]

$$Nu = 0.27 [1.682 \times 10^9]^{0.25}$$

$$Nu = 54.68$$

$$\text{Step 6. Nusselt Number, } Nu = \frac{h_l L_c}{k}$$

$$54.68 = \frac{h_u \times 0.05}{0.683}$$

$$h_l = 746.94 \text{ W/m}^2\text{K}$$

Lower surface heated, heat transfer coefficient,  $h_l = 746.94 \text{ W/m}^2\text{K}$

Step 7. Total heat transfer,  $Q = (h_u + h_l) \times A \times \Delta T$

$$= (h_u + h_l) \times W \times L \times (T_w - T_\infty)$$
$$= (2419.7 + 746.94) \times 0.10 \times (150 - 75)$$

Heat transfer,  $Q = 23749.8 \text{ W}$

**9. Atmospheric air at 275 K and a free stream velocity of 20 m/s flows over a flat plate 1.5 m long that is maintained at a uniform temperature of 325 K. Calculate the average heat transfer coefficient over the region where the boundary layer is laminar, the average heat transfer coefficient over the entire length of the plate and the total heat transfer rate from the plate to the air over the length 1.5 m and width 1 m. Assume transition occurs at  $Re_c = 2 \times 10^5$ .**

**Given:** Fluid temperature,  $T_\infty = 275 \text{ K} = 2^\circ\text{C}$

Velocity,  $U = 20 \text{ m/s}$

Length,  $L = 1.5 \text{ m}$

Plate surface temperature,  $T_w = 325 \text{ K} = 52^\circ\text{C}$

Width,  $W = 1 \text{ m}$

Critical Reynolds number,  $Re_c = 2 \times 10^5$

- To find:**
1. Average heat transfer coefficient,  $h_l$  [Boundary layer is laminar]
  2. Average heat transfer coefficient,  $h_t$  [Entire length of the plate]
  3. Total heat transfer rate,  $Q$ .

**Solution:**

Step 1. Film temperature,  $T_f = \frac{T_w + T_\infty}{2}$

$$= \frac{52 + 2}{2}$$

$$T_f = 27^\circ\text{C}$$

Properties of air at  $27^\circ\text{C} \approx 25^\circ\text{C}$

[From HMT data book, Page No. 34 ]

$$\rho = 1.185 \text{ Kg/m}^3$$

$$\nu = 15.53 \times 10^{-6} \text{ m}^2/\text{s}$$

$$\text{Pr} = 0.702$$

$$k = 0.02634 \text{ W/mK}$$

Case (i): Reynolds number,  $\text{Re} = \frac{UL}{\nu}$

Transition occurs at  $\text{Re}_c = 2 \times 10^5$

ie., Flow is laminar upto Reynolds number value is  $2 \times 10^5$ , after that flow is turbulent.

$$2 \times 10^5 = \frac{20 \times L}{15.53 \times 10^{-6}}$$

$$L = 0.155 \text{ m}$$

For flat plate, laminar flow,

Step 2. Local Nusselt number,  $\text{Nu}_x = 0.332 (\text{Re})^{0.5} (\text{Pr})^{0.333}$

[From HMT data book, Page No. 113]

$$\text{Nu}_x = 0.332 (2 \times 10^5)^{0.5} (0.702)^{0.333}$$

$$\text{Nu}_x = 131.97$$

Step 3. Local Nusselt Number,  $\text{Nu}_x = \frac{h_x L}{k}$

$$131.97 = \frac{h_x \times 0.155}{0.02634}$$

$$h_x = 22.42 \text{ W/m}^2\text{K}$$

Local heat transfer coefficient, $h_x = 22.42 \text{ W/m}^2\text{K}$
--

Step 4. Average heat transfer coefficient,  $h = 2 \times h_x$

$$= 2 \times 22.42$$

$$= 44.84 \text{ W/m}^2\text{K}$$

Case (ii):

Step 5. Reynolds number,  $\text{Re}_L$  [For entire length] =  $\frac{UL}{\nu}$

$$= \frac{20 \times 1.5}{15.53 \times 10^{-6}}$$

$$= 1.93 \times 10^6 > 5 \times 10^5$$

Since  $Re_L > 5 \times 10^5$ , flow is turbulent.

For flat plate, laminar-turbulent combined flow,

Step 6. Average Nusselt number,  $Nu = (Pr)^{0.333} [0.037 (Re_L)^{0.8} - 871]$

$$Nu = (0.702)^{0.333} [0.037 (1.93 \times 10^6)^{0.8} - 871]$$

$$Nu = 2737.18$$

Step 7. Nusselt number,  $Nu = \frac{hL}{k}$

$$2737.18 = \frac{h \times 1.5}{0.02634}$$

$$h = 48.06 \text{ W/m}^2\text{K}$$

Average heat transfer coefficient for turbulent flow,  $h_t = 48.06 \text{ W/m}^2\text{K}$

Step 8. Total heat transfer rate,  $Q = h_t \times A \times \Delta T$

$$= h_t \times W \times L \times (T_w - T_\infty)$$

$$= 48.06 \times 1 \times 1.5 \times (52 - 2)$$

$Q = 3604.5 \text{ W}$

**10. A steam pipe 10 cm outside diameter runs horizontally in a room at 23°C. Take the outside surface temperature of pipe as 165°C. Determine the heat loss per metre length of the pipe. [Dec 2004]**

**Given:** Diameter of the pipe,  $D = 10 \text{ cm} = 0.10 \text{ m}$

Ambient air temperature,  $T_\infty = 23^\circ\text{C}$

Wall temperature,  $T_w = 165^\circ\text{C}$

To find: Heat loss per metre length.

Solution:

Step 1. Film temperature,  $T_f = \frac{T_w + T_\infty}{2}$

$$= \frac{165 + 23}{2}$$

$T_f = 94^\circ\text{C}$

Properties of air at  $94^\circ\text{C} \approx 95^\circ\text{C}$

[From HMT data book, Page No. 34]

$$\rho = 0.959 \text{ Kg/m}^3$$

$$\nu = 22.615 \times 10^{-6} \text{ m}^2/\text{s}$$

$$\text{Pr} = 0.689$$

$$k = 0.03169 \text{ W/mK}$$

Step 2. Coefficient of thermal expansion,  $\beta = \frac{1}{T_f \text{ in K}}$

$$= \frac{1}{94+273}$$
$$= 2.72 \times 10^{-3} \text{ K}^{-1}$$

$$\beta = 2.72 \times 10^{-3} \text{ K}^{-1}$$

Step 3. Grashof Number,  $\text{Gr} = \frac{g \times \beta \times D^3 \times \Delta T}{\nu^2}$

[From HMT data book, Page No. 135]

$$\text{Gr} = \frac{9.81 \times 2.72 \times 10^{-3} \times (0.10)^3 \times (165-23)}{(22.615 \times 10^{-6})^2}$$

$$\text{Gr} = 7.40 \times 10^6$$

$$\text{GrPr} = 7.40 \times 10^6 \times 0.689$$

$$\text{GrPr} = 5.09 \times 10^6$$

For horizontal cylinder, Nusselt number,  $\text{Nu} = C [\text{GrPr}]^m$

[From HMT data book, Page No. 138]

$\text{GrPr} = 5.09 \times 10^6$ , corresponding  $C = 0.48$ , and  $m = 0.25$

$$\text{Nu} = 0.48 [5.09 \times 10^6]^{0.25}$$

$$\text{Nu} = 22.79$$

Step 4. Nusselt number,  $\text{Nu} = \frac{hD}{k}$

$$22.79 = \frac{h \times 0.10}{0.03169}$$

$$h = 7.22 \text{ W/m}^2\text{K}$$

Step 5. Heat loss,  $Q = hA\Delta T$

$$= h \times \pi DL(T_w - T_\infty)$$

$$\frac{Q}{L} = h \times \pi \times D \times (T_w - T_\infty)$$

$$= 7.22 \times \pi \times 0.10 \times (165 - 23)$$

$$\frac{Q}{L} = 322.08 \text{ W/m}$$

$$\text{Heat loss per metre length, } \frac{Q}{L} = 322.08 \text{ W/m}$$

1. Consider the flow of oil at 20° C in a 30cm diameter pipeline at an average velocity of 2 m/s. a 200m long section of the pipeline passes through icy waters of a lake at 0° C. Measurements indicate that the surface temperature of the pipe is very nearly 0° C. Disregarding the thermal resistance of the pipe material determine (a) the temperature of the oil when the pipe leaves the lake, (b) the rate of heat transfer from the oil, and (c) the pumping power required to overcome the pressure losses and to maintain the flow of the oil in the pipe.

### Solution

Oil flows in a pipeline that passes through icy waters of a lake at 0° C. The exit temperature of the oil, the rate of heat loss, and the pumping power needed to overcome pressure losses are to be determined.

### Assumptions

1. Steady operating conditions exist.
2. The surface temperature of the pipe is very nearly 0° C.
3. The thermal resistance of the pipe is negligible.
4. The inner surfaces of the pipeline are smooth.
5. The flow is hydrodynamically developed when the pipeline reaches the lake.

### Properties

We do not know the exit temperature of the oil, and thus we cannot determine the bulk mean temperature, which is the temperature at which the properties of oil are to be evaluated. The mean temperature of the oil at the inlet is 20°C, and we expect this temperature to drop somewhat as a result of heat loss to the icy waters of the lake. We evaluate the properties of the oil at the inlet temperature, but we will repeat the calculations, if necessary, using properties at the evaluated bulk mean temperature. At 20° C from HMT data book

$$\rho = 888 \text{ kg/m}^3 \quad U = 901 \times 10^{-6} \text{ m}^2/\text{s}$$

$$k = 0.145 \text{ W/m } ^\circ\text{C} \quad C_p = 1880 \text{ J/kg } ^\circ\text{C}$$

$$\text{Pr} = 10,400$$

$$R_e = \frac{UD}{\nu} = \frac{2 \times 0.3}{901 \times 10^{-6}} = 666$$

which is less than the critical Reynolds number of 2300. Therefore, the flow is

laminar, and we assume thermally developing flow and determine the nusselt number from

$$\begin{aligned} \text{Nu} &= \frac{hD}{k} = 3.66 + \frac{0.065 (D/L) \text{Re} \text{Pr}}{1 + 0.04 [(D/L) \text{Re} \text{Pr}]^{2/3}} \\ &= 3.66 + \frac{0.065 (0.3/200) \times 666 \times 10400}{1 + 0.04 [(0.3/200) \times 666 \times 10400]^{2/3}} = 37.3 \end{aligned}$$

This nusselt number is considerably higher than the fully developed value of 3.66 then

$$h = \frac{k}{n} \text{Nu} = \frac{0.0145}{0.3} (37.3) = 18.0 \frac{\text{W}}{\text{m}^2} \text{ } ^\circ\text{C}$$

also we determine the exit temperature of air from

$$T_e = T_s - (T_s - T_i) \exp(-h A_s / m C_p)$$

here

$$A_s = PL = \pi DL = \pi (0.3 \text{ m})(200 \text{ m}) = 188.5 \text{ m}^2$$

$$m = \rho V = (1.009 \text{ kg/m}^3)(0.15 \text{ m}^3/\text{s}) = 0.151 \text{ kg/s}$$

Substitute  $A_s$  and  $m$  in  $T_e$

$$T_e = 60 - (60 - 80) \exp(-13.5 \times 6.4 / 0.151 \times 1008) = 71.3 \text{ } ^\circ\text{C}$$

Then the logarithmic mean temperature difference and the rate of heat loss from the air become

$$\Delta T_{\ln} = \frac{T_i - T_e}{\ln \frac{T_s - T_e}{T_s - T_i}} = -15.2 \text{ } ^\circ\text{C}$$

$$Q = h A_s \Delta T_{\ln} = (13.5 \text{ W/m}^2 \text{ } ^\circ\text{C})(6.4 \text{ m}^2)(-15.2 \text{ } ^\circ\text{C}) = -1313 \text{ W}$$

Therefore, air will lose heat at a rate of 1313 W as it flows through the duct in the attic.

**2. In condenser water flows through two hundred thin walled circular tubes having inner diameter 20mm and length 6 m. the mass flow rate of water is 160 kg/s. the water enters at 30° C and leaves at 50 ° C. Calculate the average heat transfer coefficient.**

**Given :**

Inner diameter  $D = 20\text{mm}$

Length  $L = 6 \text{ m}$

Mass flow rate  $m = 160 \text{ kg/s}$

Inlet water temperature  $T_{mi} = 30^\circ \text{C}$

Outlet water temperature,  $T_{mo} = 50^\circ \text{C}$

To find: Heat transfer coefficient (h)

Solution:

$$\text{Bulk mean temperature } T_m = \frac{T_{mi} + T_{mo}}{2} = \frac{30 + 50}{2} = 40^\circ \text{C}$$

Properties of water at  $40^\circ \text{C}$  [ from HMT data boo page no 21]

$$\rho = 995 \text{ kg/m}^3$$

$$\nu = 0.657 \times 10^{-6} \text{ m}^2/\text{s}$$

$$\text{Pr} = 4.340$$

$$k = 0.628 \text{ W/mK}$$

$$C_p = 4178 \text{ J/kg K}$$

$$\text{Reynolds Number } Re = UD/\nu$$

$$m = \rho AU$$

$$\text{Velocity } U = m/\rho A$$

$$= \frac{\left(\frac{160}{200}\right)}{995 \times \frac{\pi}{4} \times 0.020^2} = 2.55 \text{ m/s} \quad (\text{no of tubes} = 200)$$

$$Re = UD/\nu$$

$$= \frac{2.55 \times 0.020}{0.657 \times 10^{-6}} = 77625.57$$

Since  $Re > 2300$ , flow is turbulent

For turbulent flow, general equation is ( $Re > 10000$ )

$$Nu = 0.023 \times Re^{0.8} Pr^n \text{ [ from HMT data boo page no 125]}$$

This is heating process so  $n = 0.4$  ( $T_{mo} > T_{mi}$ )

$$Nu = 0.023 \times 77625.57^{0.8} 4.340^{0.4}$$

$$Nu = 337.8$$

$$Nu = \frac{hD}{k}$$

$$337.8 = \frac{h \times 0.020}{0.628}$$

Heat transfer coefficient $h = 10606.9 \text{ w/m}^2\text{K}$
---

# UNIT 3

## **UNIT: III PHASE CHANGE HEAT TRANSFER AND HEAT EXCHANGERS**

### **1. What is burnout point in boiling heat transfer? Why is it called so? (May/June 2013)**

In the Nucleate boiling region, a point at which heat flow is maximum is known as burnout point. Once we cross this point, large temperature difference is required to get the same heat flux and most material may burn at this temperature. Most of the boiling heat transfer heaters are operated below the burnout heat flux to avoid that disastrous effect.

### **2. Define NTU and LMTD of a heat exchanger. (May/June 2013 & May/June 2016)**

**LMTD** (Logarithmic Mean Temperature Difference)

The temperature difference between the hot and cold fluids in the heat exchanger varies from point in addition various modes of heat transfer are involved. Therefore based on concept of appropriate mean temperature difference, also called logarithmic mean temperature difference, the total heat transfer rate in the heat exchanger is expressed as

$$Q = U A (\Delta T)_m$$

Where U – Overall heat transfer coefficient W/m<sup>2</sup>K

A – Area m<sup>2</sup>

( $\Delta T$ )<sub>m</sub> – Logarithmic mean temperature difference.

**NTU** (No. of Transfer Units)

It is used to calculate the rate of heat transfer in heat exchangers, when there is insufficient information to calculate the Log-Mean Temperature Difference (LMTD). In heat exchanger analysis, if the fluid inlet and outlet temperatures are specified or can be determined, the LMTD method can be used; but when these temperatures are not available The NTU or The Effectiveness method is used.

**3. What are the different regimes involved in pool boiling? (May/June 2014)**

The different boiling regimes observed in pool boiling are

1. Interface evaporation
2. Nucleate boiling
3. Film boiling.

**4. Write down the relation for overall heat transfer coefficient in heat exchanger with fouling factor. (May/June 2014)**

Overall heat transfer coefficient in heat exchanger

$$\frac{1}{U_o} = \frac{1}{h_o} + R_{fo} + \frac{r_o}{k} \ln \frac{r_o}{r_i} + \frac{r_o}{r_i} R_{fi} + \frac{r_o}{r_i} \frac{1}{h_i}$$

Where  $R_{fi}$  and  $R_{fo}$  are the fouling factors at inner and outer surfaces.

[HMT Data Book, P.No.157]

**5. How heat exchangers are classified? (May/June 2015)**

The heat exchangers are classified as follows

1. Direct contact heat exchangers
2. Indirect contact heat exchangers
3. Surface heat exchangers
4. Parallel flow heat exchangers
5. Counter flow heat exchangers
6. Cross flow heat exchangers
7. Shell and tube heat exchangers
8. Compact heat exchangers.

**6. What are the limitations of LMTD method? Discuss the advantage of NTU over the LMTD method. (May/June 2015 & Nov/Dec 2012 & Nov/Dec 2013)**

The LMTD method cannot be used for the determination of heat transfer rate and outlet temperature of the hot and cold fluids for prescribed fluid mass flow rates and inlet temperatures when the type and size of heat exchanger are specified.

Effectiveness NTU is superior for the above case because LMTD requires tedious iterations for the same.

**7. Differentiate between pool and forced convection boiling. (Nov/Dec 2012 & Nov/Dec 2013 & Nov/Dec 2015) (NOV/DEC 2016)**

Boiling is called pool boiling in the absence of bulk fluid flow, and flow boiling (or forced convection boiling) in the presence of it.

In pool boiling, the fluid is stationary, and any motion of the fluid is due to natural convection currents and the motion of the bubbles due to the influence of buoyancy. Example: Boiling of water in a pan on top of a stove.

**8. What is pool boiling? Give an example for it. (Nov/Dec 2014)**

If heat is added to a liquid from a submerged solid surface, the boiling process referred to as pool boiling. In this case the liquid above the hot surface is essentially stagnant and its motion near the surface is due to free convection and mixing induced by bubble growth and detachment.

Example: Boiling of water in a pan on top of a stove.

**9. What do you understand by fouling and effectiveness? (Nov/Dec 2014 & Nov/Dec 2015 )**

The surfaces of heat exchangers do not remain clean after it has been in use for some time. The surfaces become fouled with scaling or deposits. The effect of these deposits affecting the value of overall heat transfer coefficient. This effect is taken care of by introducing an additional thermal resistance called the fouling resistance or fouling factor.

**10. Define effectiveness. (May/June 2016)**

The heat exchanger effectiveness is defined as the ratio of actual heat transfer to the maximum possible heat transfer.

$$\text{Effectiveness } \varepsilon = \frac{\text{Actual heat transfer}}{\text{Maximum possible heat transfer}}$$

**11. What is meant by sub-cooled and saturated boiling? (Nov/Dec 2015)**

The sub-cooled boiling or saturated boiling, depending on the bulk liquid temperature.

Sub-cooled boiling:

There is sharp increase in temperature near to the surface but through most of the liquid, temperature remains close to saturation temperature. ( $T_{\alpha} < T_{\text{sat}}$ )

Saturated boiling:

When the temperature of the liquid equals to the saturation temperature. ( $T_{\alpha} = T_{\text{sat}}$ )

**12. What is a compact heat exchanger? Give applications. (May/June 2016)**

Special purpose heat exchangers called compact heat exchangers. They are generally employed when convective heat transfer coefficient associated with one of the fluids is much smaller than that associated with the other fluid.

In variety of applications including,

- Compressed Gas / Water coolers
- Condensers and evaporators for chemical and technical processes of all kinds.
- Oil and water coolers for power machines
- Refrigeration and air-conditioning units

**13. What are the assumptions made in Nusselt theory of condensation? (May/June 2016)**

1. The plate is maintained at a uniform temperature which is less than the saturation temperature of vapour. ( $T_w < T_{\text{sat}}$ )
2. Fluid properties are constant.
3. The shear stress at the liquid vapour interface is negligible.
4. The heat transfer across the condensate layer is by pure conduction and the temperature distribution is linear.

**14. How fouling affect the rate of heat transfer? (May/June 2016)**

"Fouling" is any kind of deposit of extraneous material that appears upon the heat transfer surface during the life time of the heat exchanger.

This fouling will cause an additional resistance to heat transfer is introduced and the operational capability of the heat exchanger is correspondingly reduced. In many cases, the deposit is heavy enough to significantly interfere with fluid flow and increase the pressure drop required to maintain the flow rate through the exchanger.

**1. Discuss briefly the pool boiling regimes of water at atmospheric pressure (May/June 2013, May/June 2014, Nov/Dec 2013)**

Boiling is classified as pool boiling or flow boiling, depending on the presence of bulk fluid motion. Boiling is called pool boiling in the absence of bulk fluid flow and flow boiling in the presence of bulk fluid motion.

Boiling takes different forms, depending on the value of the excess temperature  $\Delta T_{\text{excess}}$ . Four different boiling regimes are observed: natural convection boiling, nucleate boiling, transition boiling, and film boiling. These regimes are illustrated on the boiling curve in fig, which is a plot of boiling heat flux versus the excess temperature.

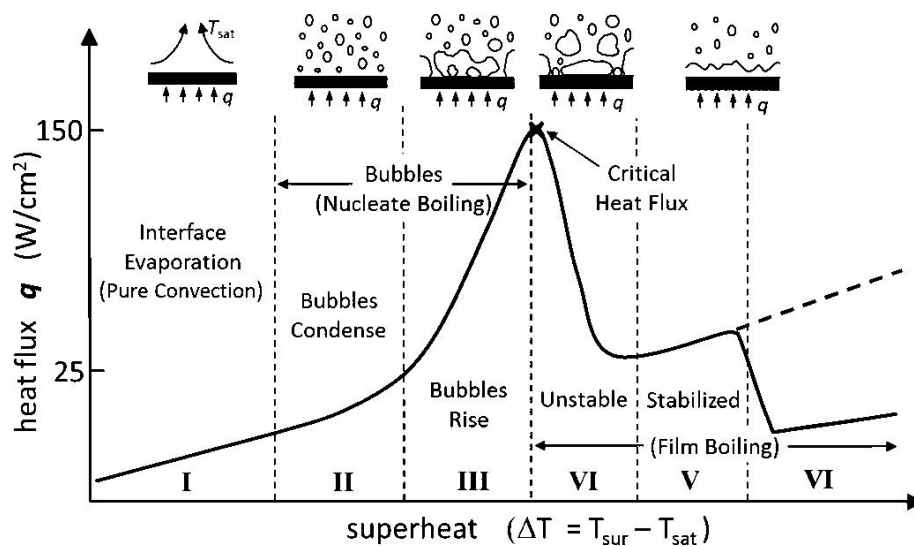

Fig: Typical boiling curve for water at 1 atmospheric pressure

**NATURAL CONVECTION BOILING (to point A on the Boiling curve)**

We know from thermodynamics that a pure substance at a specified pressure starts boiling when it reaches the saturation temperature at that

pressure. But in practice we do not see any bubbles forming on the heating surface until the liquid is heated a few degrees above the saturation temperature (about 2 to 6° C for water). Therefore, the liquid is slightly superheated in this case and evaporates when it rises to the free surface. The fluid motion in this mode of boiling is governed by natural convection currents, and heat transfer from the heating surface to the fluid is by natural convection. For the conditions of fig, natural convection boiling ends at excess temperature of about 5° C.

### **NUCLEATE BOILING (between points A and C)**

The first bubbles start forming at point A of the boiling curve at various preferential sites on the heating surface. Point A is referred to as the onset of nucleate boiling (ONB). The bubbles form at an increasing rate at an increasing number of nucleation sites as we move along the boiling curve toward point C. From fig nucleate boiling exists in the range from about 5° C to about 30°C.

The nucleate boiling regime can be separated into two distinct regions. In regions A-B ( $5^{\circ}\text{C} \leq \Delta T_{\text{excess}} \leq 10^{\circ}\text{C}$ ), isolated bubbles are formed at various preferential nucleation sites on the heated surface. But these bubbles are dissipated in the liquid shortly after they separate from the surface. The space vacated by the rising bubbles is filled by the liquid in the vicinity of the heater surface, and the process is repeated. The stirring and agitation caused by the entrainment of the liquid to the heater surface is primarily responsible for the increased heat transfer coefficient and heat flux in this region of nucleate boiling.

In region B-C ( $10^{\circ}\text{C} \leq \Delta T_{\text{excess}} \leq 30^{\circ}\text{C}$ ), the heater temperature is further increased, and bubbles form at such great rates at such a large number of nucleation sites that they form numerous continuous columns of vapour in the liquid. These bubbles move all the way up to the free surface, where they break up and release their vapor content. The large heat fluxes obtainable in this region.

At large values of  $\Delta T_{\text{excess}}$ , the rate of evaporation at the heater surface reaches such high values that a large fraction of the heater surface

is covered by bubbles, making it difficult for the liquid to reach the heater surface and wet it. Consequently, the heat flux increases at a lower rate with increasing  $\Delta T_{\text{excess}}$ , and reaches a maximum at point C. the heat flux at this point is called the critical heat flux.

### **TRANSITION BOILING (between points C and D)**

As the heater temperature and thus the  $\Delta T_{\text{excess}}$ , is increased past point C, the heat flux decreases, as shown in fig. this is because a large fraction of the heater surface is covered by a vapour film, which acts as an insulation due to the low thermal conductivity of the vapour relative to that of the liquid. In the transition boiling regime, both nucleate and film boiling partially occur. Nucleate boiling at point C is completely replaced by film boiling at point D. for water, transition boiling occurs over the excess temperature range from about 30°C to about 120°C.

### **FILM BOILING (beyond point D)**

In this region the heater surface is completely covered by a continuous stable vapour film. Point D, where the heat flux reaches a minimum, is called the Leidenforst point. The liquid droplets on a very hot surface jump around and slowly boil away. The presence of a vapour film between the heater surface and the liquid is responsible for the low heat transfer rates in the film boiling region. The heat transfer rate increases with increasing excess temperature as a result of heat transfer from the heated surface to the liquid through the vapour film by radiation, which becomes significant at high temperatures.

- 2. Water is to be boiled at atmospheric pressure in a polished copper pan by means of an electric heater. The diameter of the pan is 0.38 m and is kept at 115° C. calculate the following 1. Power required boiling the water 2. Rate of evaporation 3. Critical heat flux. (Nov/Dec 2012, Nov/Dec 2015)**

**Given:**

Diameter,  $d = 0.38 \text{ m}$ ;

Surface temperature,  $T_w = 115^\circ \text{ C}$ .

**To find:**

1. Power required, (p)
2. Rate of evaporation, (ṁ)
3. Critical heat flux, (Q/A)

**Solution:****Step 1:**

Need to find the nucleate pool boiling or film pool boiling process.

$\Delta T = \text{Excess Temperature} = T_w - T_{\text{sat}} = \text{Answer}$ , which is less than  $50^\circ \text{C}$  then it is Nucleate pool boiling or greater than  $50^\circ \text{C}$  then it is film pool boiling.

$$\Delta T = T_w - T_{\text{sat}}$$

We know that saturation temperature of water is  $100^\circ \text{C}$ . i.e.  $T_{\text{sat}} = 100^\circ \text{C}$

$\Delta T = 115 - 100 = 15^\circ \text{C}$  so this is nucleate pool boiling process.

**Step 2:**

Need to find the properties of water at  $100^\circ \text{C}$ .

(From HMT data book page No. 21)

Density,  $\rho_l = 961 \text{ kg/m}^3$

Kinematic viscosity,  $\nu = 0.293 \times 10^{-6} \text{ m}^2/\text{s}$

Prandtl Number,  $P_r = 1.740$

Specific heat,  $C_{pl} = 4216 \text{ J/kg K}$

Dynamic viscosity,  $\mu_l = \rho_l \times \nu = 961 \times 0.293 \times 10^{-6} = 281.57 \times 10^{-6} \text{ Ns/m}^2$

Enthalpy of evaporation,  $h_{fg} = 2256.9 \text{ KJ/kg}$  (from steam table)

Specific volume of vapour,  $\nu_g = 1.673 \text{ m}^3/\text{kg}$

Density of vapour,  $\rho_v = (1/\nu_g) = 0.597 \text{ kg/m}^3$

**Step 3:**

Need to find the heat flux, power

Heat flux,  $\frac{Q}{A} = \mu_l \times h_{fg} \left[ \frac{g \times (\rho_l - \rho_v)}{\sigma} \right]^{0.5} \times \left[ \frac{C_{pl} \times \Delta T}{C_{sf} \times h_{fg} P_r^n} \right]^3$  .....1 (from HMT data book page no. 142)

Where  $\sigma$  = surface tension for liquid vapour interface at  $100^\circ \text{C}$ .

$\sigma = 0.0588 \text{ N/m}$

(from HMT data book page no. 144)

For water – copper  $\rightarrow C_{sf}$  = surface fluid constant = 0.013 and  $n=1$  for water  
(from HMT data book page no.143)

Substitute the  $\mu_l, h_{fg}, \rho_l, \rho_v, C_{pl}, \Delta T, C_{sf}, n$  and  $P_r$  values in equation 1

$$\frac{Q}{A} = 4.83 \times 10^5 \text{ W/m}^2$$

$$\text{Heat transfer } Q = 4.83 \times 10^5 \times A$$

$$\text{Area } A = \left(\frac{\pi}{4}\right)d^2 = 0.113 \text{ m}^2$$

Power = 54.7 kW
-----------------

**Step 4:**

Need to find Rate of evaporation, ( $\dot{m}$ )

$$\text{Heat transferred } Q = \dot{m} \times h_{fg}$$

Substitute  $Q$  and  $h_{fg}$

$\dot{m} = 0.024$ kg/s
---------------------------

**Step 5:**

Need to find the critical flux

For nucleate pool boiling, critical heat flux,

$$\frac{Q}{A} = 0.18 \times h_{fg} \times \rho_v \left[ \frac{\sigma \times g \times (\rho_l - \rho_v)}{\rho_v^2} \right]^{0.25}$$

(from HMT data book page no. 142)

Critical heat flux, $q = \frac{Q}{A} = 1.52 \times 10^6 \text{ W/m}^2$
--

- 3. A wire of 1 mm diameter and 150mm length is submerged horizontally in water at 7 bar. The wire carries a current of 131.5 ampere with an applied voltage of 2.15 Volt. If the surface of the wire is maintained at 180° C, calculate the heat flux and the boiling heat transfer coefficient.(May/June 2014 Reg 2008)**

**Given:**

Diameter,  $D = 1 \text{ mm} = 1 \times 10^{-3} \text{ m}$ ;

Length,  $L = 150 \text{ mm} = 150 \times 10^{-3} \text{ m}$ ;

Pressure,  $P = 7 \text{ bar}$

Voltage,  $V = 2.15 \text{ V}$

Current,  $I = 131.5 \text{ amps}$

$T_w = 180^\circ \text{ C}$

**To find:**

1. Heat flux,  $\frac{Q}{A}$
2. Heat transfer coefficient,  $h$

**Solution:**

**Step 1:**

Need to find heat flux

$$Q = V \times I = 2.15 \times 131.5 = 282.72 \text{ W}$$

$$A = \pi DL = \pi \times 1 \times 10^{-3} \times 150 \times 10^{-3} = 471.23 \times 10^{-6} \text{ m}^2$$

$$\text{Heat flux} = \frac{Q}{A} = 282.72 / 471.23 \times 10^{-6} = 599.950 \times 10^3 \text{ W/m}^2$$

$$\frac{Q}{A} = 599.950 \times 10^3 \text{ W/m}^2$$

**Step 2:**

Need to find the heat transfer coefficient  $h$

At pressure  $P = 7 \text{ bar}$ :  $\Delta T = 180 - 100 = 80^\circ \text{ C}$

Heat transfer coefficient,  $h = 5.56 (\Delta T)^3$

(From HMT data book page no: 143)

$$h = 2846720 \text{ W/m}^2 \text{ K}$$

Heat transfer coefficient other than atmospheric pressure

$$h_p = h P^{0.4} = 2846720 \times 7^{0.4} = 6.19 \times 10^6 \text{ W/m}^2 \text{ K}$$

$$h_p = 6.19 \times 10^6 \text{ W/m}^2 \text{ K}$$

**4. A vertical cooling fin approximating a flat plate 40 cm in height is exposed to saturated steam at atmospheric pressure. The fin is maintained at a temperature of  $90^\circ \text{ C}$ . estimate the thickness of the film at the bottom of the fin, overall heat transfer coefficient and heat transfer rate after incorporating McAdam's correction, the rate of condensation of steam. (Nov/Dec 2015 Reg 2008)**

**Given:**

Height (or) Length,  $L = 40 \text{ cm} = 0.4 \text{ m}$

Surface temperature,  $T_w = 90^\circ \text{ C}$

**To find:**

1. The film thickness  $\delta_x$
2. Overall heat transfer coefficient  $h$  (McAdam's correction)
3. Heat transfer rate  $Q$
4. Rate of condensation of steam  $\dot{m}$

**Solution:****Step 1:**

We know that, saturation temperature of water is  $100^\circ \text{ C}$ , i.e.  $T_{\text{sat}} = 100^\circ \text{ C}$

$h_{fg} = 2256.9 \text{ kJ/kg}$  (from steam table)

We know that

Film temperature,  $T_f = \frac{T_w + T_{\text{sat}}}{2} = 95^\circ \text{ C}$

Properties of saturated water at  $95^\circ \text{ C}$  (from HMT data book page no: 21)

Density,  $\rho_l = 967.5 \text{ kg/m}^3$

Kinematic viscosity,  $\nu = 0.328 \times 10^{-6} \text{ m}^2/\text{s}$

Specific heat,  $C_{pl} = 4205.5 \text{ J/kg K}$

Thermal conductivity  $K = 0.674 \text{ W/mk}$

Dynamic viscosity,  $\mu_l = \rho_l \times \nu = 967.5 \times 0.328 \times 10^{-6} = 3.173 \times 10^{-4} \text{ Ns/m}^2$

**Step 2:**

We need to find the film thickness

$$\delta_x = \left[ \frac{4 \mu K x (T_{\text{sat}} - T_w)}{g h_{fg} \rho_l^2} \right]^{0.25} \quad \text{(from HMT data book page no: 148)}$$

substitute all appropriate property value in above formula

$\delta_x = 1.13 \times 10^{-4} \text{ m}$
--

**Step 3:**

We need to find the heat transfer coefficient  $h$

For vertical surface laminar flow (assume) or find by Re-Reynolds number

$Re = \frac{4 \dot{m}}{P \mu}$  here  $P = \text{perimeter}$ ;  $Re > 1800$  then that flow is turbulent flow,

$Re < 1800$  then that flow is laminar flow,

$$h = 0.943 \left[ \frac{k^3 \times \rho^2 \times g h_{fg}}{\mu \times L \times (T_{sat} - T_w)} \right]^{0.25} \quad (\text{from HMT data book page no: 148})$$

The factor 0.943 may be replaced by 1.13 for more accurate result as suggested by Mc Adams

$$h = 1.13 \left[ \frac{k^3 \times \rho^2 \times g h_{fg}}{\mu \times L \times (T_{sat} - T_w)} \right]^{0.25}$$

Substitute all the properties in above formula

$$h = 1495.3 \text{ W/m}^2 \text{ K}$$

#### Step 4:

We need to find the heat transfer rate Q

$$Q = h A (T_{sat} - T_w) = h L W (T_{sat} - T_w)$$

$$Q = 1495.3 \times 0.4 \times 1 \times 10 = 5981.26 \text{ W}$$

$$Q = 5981.26 \text{ W}$$

#### Step 5:

We need to find the rate of condensation of steam  $\dot{m}$

$$Q = \dot{m} h_{fg}$$

$$\dot{m} = Q/h_{fg}$$

$$\dot{m} = 0.00265 \text{ kg/s}$$

**5. A condenser is to be designed to condense 600 kg/h of dry saturated steam at a pressure of 0.12 bar. A square array of 400 tubes, each of 8 mm diameters is to be used. The tube surface is maintained at 30° C. Calculate the heat transfer coefficient and the length of each tube. (April/May 2015) (NOV/DEC 2013)**

**Given:**

$$\dot{m} = 600 \text{ kg/h} = 0.166 \text{ kg/s}$$

$$\text{Pressure } P = 0.12 \text{ bar}$$

$$\text{No. of tubes} = 400$$

$$\text{Diameter, } D = 8 \text{ mm} = 8 \times 10^{-3} \text{ m}$$

$$\text{Surface temperature, } T_w = 30^\circ \text{ C.}$$

**To find:**

1. Heat transfer coefficient h
2. Length

**Solution:**

**Step 1:**

We need find the properties of steam at 0.12 bar (from steam table)

$$T_{sat} = 49.45 \text{ }^\circ\text{C}.$$

$$h_{fg} = 2384.3 \times 10^3 \text{ J/kg}$$

$$\text{Film temperature, } T_f = \frac{T_w + T_{sat}}{2} = 39.72^\circ\text{C} = 40^\circ\text{C}$$

Properties of saturated water at 40°C (from HMT data book page no: 21)

$$\text{Density, } \rho_l = 995 \text{ kg/m}^3$$

$$\text{Kinematic viscosity, } \nu = 0.657 \times 10^{-6} \text{ m}^2/\text{s}$$

$$\text{Thermal conductivity } K = 0.628 \text{ W/mk}$$

$$\text{Dynamic viscosity, } \mu_l = \rho_l \times \nu = 995 \times 0.657 \times 10^{-6} = 653.7 \times 10^{-6} \text{ Ns/m}^2$$

With 400 tubes, a 20 × 20 tube of square array could be formed

$$N = \sqrt{400} = 20$$

**Step 2:**

We need to find the heat transfer coefficient h

$$h = 0.728 \left[ \frac{k^3 \times \rho^2 \times g \times h_{fg}}{\mu \times N D \times (T_{sat} - T_w)} \right]^{0.25} \quad (\text{from HMT data book page no: 148})$$

$h = 5304.75 \text{ W/m}^2 \text{ K}$
---------------------------------------

**Step 3:**

$$Q = h A (T_{sat} - T_w) = h D L (T_{sat} - T_w) = 1.05 \times 10^6 \text{ L} \text{----- 1}$$

We know that

$$Q = \dot{m} h_{fg} = 0.3957 \times 10^6 \text{ W} \text{----- 2}$$

Equating (1) and (2) We get,

$L = 0.37$
------------

m

6. In a double pipe counter flow heat exchanger, 10000 kg/hr of an oil having a specific heat of 2095 J/kg-k is cooled from 80°C to 50°C by 800 kg/hr of water entering at 25°C. Determine the heat exchanger area

for an overall heat transfer co-efficient of  $300 \text{ W/m}^2\text{k}$ . Take  $C_p$  for water as  $4180 \text{ J/kg-k}$ .

**Given:**

Hot fluid – oil ( $T_1-T_2$ )                  Cold fluid - water ( $t_1-t_2$ )

The mass flow rate of oil (Hot fluid),  $m_h = 10000 \text{ kg/hr}$

$$= \frac{10000 \text{ kg}}{3600 \text{ s}}$$

$$m_h = 2.277 \text{ kg/s}$$

Specific heat of oil,  $C_{ph} = 2095 \text{ J/kg-k}$

Entry temperature of oil,  $T_1 = 80^\circ\text{C}$

Exit temperature of oil,  $T_2 = 50^\circ\text{C}$

Mass flow rate of water (Cold fluid),  $m_c = 8000 \text{ kg/hr}$

$$= \frac{8000 \text{ kg}}{3600 \text{ s}}$$

$$m_c = 2.22 \text{ kg/s}$$

Entry temperature of water,  $t_1 = 25^\circ\text{C}$

Overall heat transfer co-efficient,  $U = 300 \text{ W/m}^2\text{k}$

Specific heat of water,  $C_{pc} = 4180 \text{ J/kg-k}$

**To find:**

Heat exchanger area,  $A$

**Solution:**

Heat lost by oil (Hot fluid) = Heat gained by water (Cold fluid)

$$Q_h = Q_c$$

$$m_h C_{ph} (T_1 - T_2) = m_c C_{pc} (t_1 - t_2)$$

$$2.277 \times 2095 (80 - 50) = 2.22 \times 4180 \times (t_2 - 25)$$

$$174.53 \times 10^3 = 9.27 \times 10^3 t_2 - 231.99 \times 10^3$$

$$t_2 = 43.85^\circ\text{C}$$

$$\text{Exit temperature of water, } t_2 = 43.85^\circ\text{C}$$

$$\text{Heat transfer, } Q = m_h C_{ph} (T_1 - T_2) \text{ or } m_c C_{pc} (t_1 - t_2)$$

$$Q = 2.22 \times 4180 \times (43.85 - 25)$$

We know that,

$$Q = 174.92 \times 10^3 \text{ W}$$

$$\text{Heat transfer, } Q = UA (\Delta T)_m \dots \dots \dots (1)$$

Where,

$(\Delta T)_m$  – Logarithmic Mean Temperature Difference.

(LMTD)

$$\begin{aligned} \text{For counter flow, } (\Delta T)_m &= \frac{[(T_1 - t_2) - (T_2 - t_1)]}{\ln \left[ \frac{T_1 - t_2}{T_2 - t_1} \right]} \\ &= \frac{[(80 - 43.85) - (50 - 25)]}{\ln \left[ \frac{80 - 43.85}{50 - 25} \right]} \end{aligned}$$

$$(\Delta T)_m = 30.23^\circ\text{C}$$

Substitute  $(\Delta T)_m$ , U and Q value in eqn (1)

$$Q = UA (\Delta T)_m$$

$$174.92 \times 10^3 = 300 \times A \times 30.23$$

$$\text{Heat exchanger area } A = 19.287 \text{ m}^2$$

**7. In a cross flow heat exchangers, both fluids are mixed, hot fluid with a specific heat of 2300 J/kg K, enters at 380°C and leaves at 300°C. Cold fluids enter at 25°C and leaves 210°C. Calculate the required surface area of heat exchanger. Take overall heat transfer co-efficient is 750 W/m<sup>2</sup>K. Mass flow rate of hot fluid is 1 Kg/s.**

Given:

- Specific heat of hot fluid  $C_{ph} = 2300 \text{ J/Kg K}$
- Entry temperature of hot fluid  $T_1 = 380^\circ \text{ C}$
- Exit temperature of hot fluid  $T_2 = 300^\circ \text{ C}$
- Entry temperature of Cold fluid  $t_1 = 25^\circ \text{ C}$
- Exit temperature of Cold fluid  $t_2 = 210^\circ \text{ C}$
- Overall heat transfer co-efficient,  $U = 750 \text{ W/m}^2\text{K}$
- The mass flow rate of hot fluid,  $m_h = 1 \text{ kg/s}$

**To find:**

Heat exchanger area (A)

**Solution:**

This is Cross flow, both fluids unmixed type heat exchanger.

For cross flow heat exchanger,

$$Q = F UA (\Delta T)_m \text{ (counter flow).....(1)}$$

[From HMT Data book page No. 152]

Where,

$(\Delta T)_m$  – Logarithmic Mean Temperature Difference for counter flow.

$$\text{For counter flow, } (\Delta T)_m = \frac{[(T_1 - t_2) - (T_2 - t_1)]}{\ln \left[ \frac{T_1 - t_2}{T_2 - t_1} \right]}$$

$$= \frac{[(380 - 210) - (300 - 25)]}{\ln \left[ \frac{380 - 210}{300 - 25} \right]}$$

$$\boxed{(\Delta T)_m = 218.3^{\circ}\text{C}}$$

$$\text{Heat transfer, } Q = m_h C_{ph} (T_1 - T_2)$$

$$Q = 1 \times 2300 \times (380 - 300)$$

$$\boxed{Q = 184 \times 10^3 \text{ W}}$$

To find correction factor F, refer HMT data book page No 162

[Single pass cross flow heat exchanger – Both fluids unmixed]

From graph,

$$X_{\text{axis value}} P = \left[ \frac{t_2 - t_1}{T_1 - t_1} \right]$$

$$= \left[ \frac{210 - 25}{380 - 25} \right] \quad \text{X axis Value is 0.52, Curve Value is 0.432,}$$

corresponding  $Y_{\text{axis}}$  Value is 0.97 i.e  $\boxed{F = 0.97}$

$$P = 0.52$$

$$\text{Curve Value } R = \left[ \frac{T_1 - T_2}{t_2 - t_1} \right]$$

$$= \left[ \frac{380 - 300}{210 - 25} \right]$$

$$R = 0.432$$

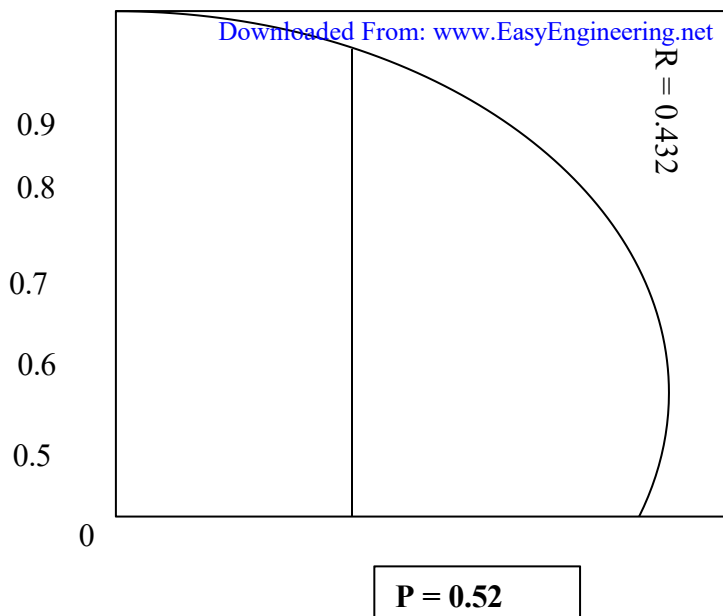

Substitute,  $Q$ ,  $F (\Delta T)_m$ , and  $U$  value in eqn (1)

$$Q = F UA (\Delta T)_m$$

$$184 \times 10^3 = 0.97 \times 750 \times A \times 218.3$$

Surface Area  $A = 1.15 \text{m}^2$

### 8. Classify the heat exchangers, draw the temperature distribution in a condenser and evaporator.

There are several types heat exchangers which may be classified on the basis of

- I. Nature of heat exchange process
- II. Relative direction of fluid motion
- III. Design and constructional features
- IV. Physical state of fluids.

#### I. Nature of heat exchange process

On the basis of the nature of heat exchange processes, heat exchangers are classified as

Direct contact heat exchangers or open heat exchangers

a) Indirect contact heat exchangers

a. Direct contact heat exchangers

The heat exchange takes place by direct mixing of hot and cold fluids.

This heat transfer is usually accompanied by mass transfer.

Ex: cooling towers, direct contact feed heaters

Gas

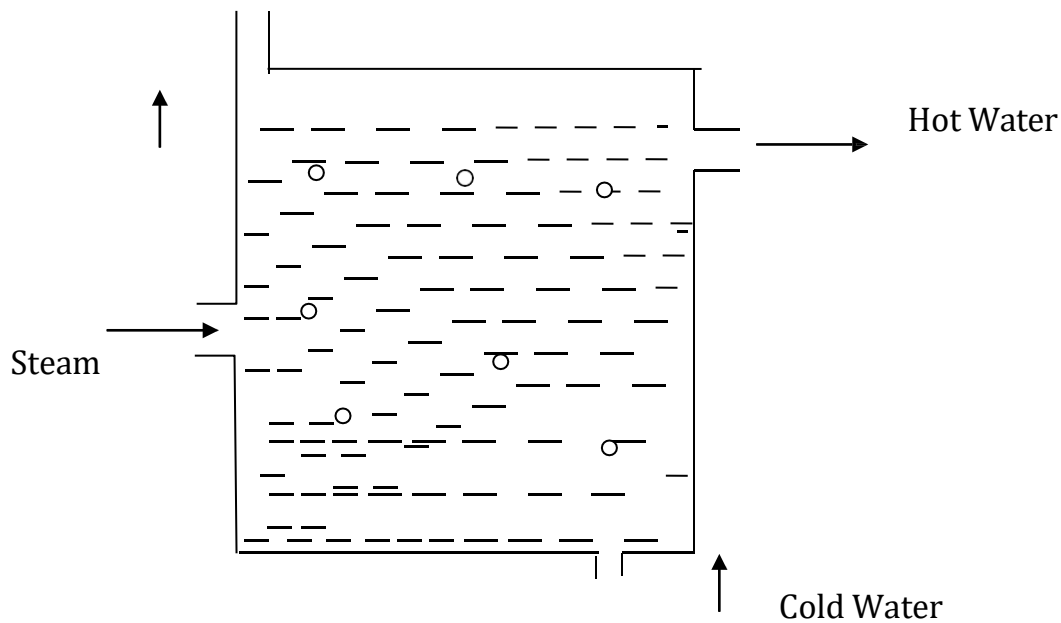

b. Indirect contact heat exchangers could be carried out by transmission through a wall which separates the two fluids

It may be classified as

i) Regenerators

ii) Recuperators

Regenerators

Hot and cold fluids flow alternately through the same space

Ex: IC engines, gas turbines

Recuperators

This is most common type of heat exchanger in which the hot and cold fluid do not come into direct contact with each other but are separated by a tube wall or a surface.

Ex: Automobile radiators, Air pre heaters, Economisers

Advantages

1. Easy construction
2. More economical
3. More surface area for heat transfer

Disadvantages

1. Less heat transfer co-efficient
2. Less generating capacity

## II. Relative direction of fluid motion

- a. Parallel flow heat exchanger
- b. Counter flow heat exchanger
- c. Cross flow heat exchanger

a) Parallel Flow – the hot and cold fluids flow in the same direction. Depicts such a heat exchanger where one fluid (say hot) flows through the pipe and the other fluid (cold) flows through the annulus.

(b) Counter Flow – the two fluids flow through the pipe but in opposite directions. A common type of such a heat exchanger. By comparing the temperature distribution of the two types of heat exchanger

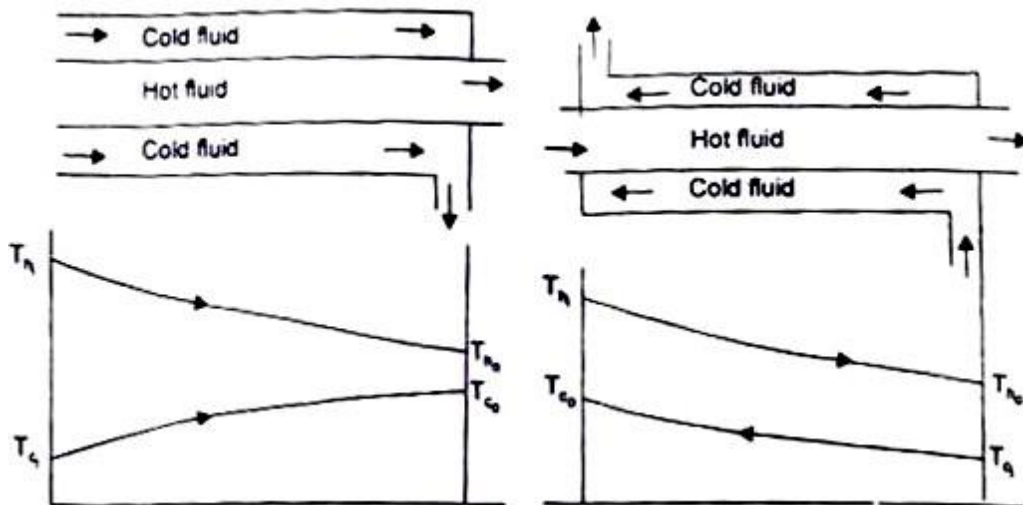

We find that the temperature difference between the two fluids is more uniform in counter flow than in the parallel flow. Counter flow exchangers give the maximum heat transfer rate and are the most favoured devices for heating or cooling of fluids. When the two fluids flow through the heat exchanger only once, it is called one-shell-pass and one-tube-pass

(c) Cross-flow - A cross-flow heat exchanger has the two fluid streams flowing at right angles to each other. illustrates such an arrangement An automobile radiator is a good example of cross-flow exchanger. These exchangers are 'mixed' or 'unmixed' depending upon the mixing or not mixing of either fluid in the direction transverse to the direction of the flow stream and the analysis of this type of heat exchanger is extremely complex because of the variation in the temperature of the fluid in and normal to the direction of flow

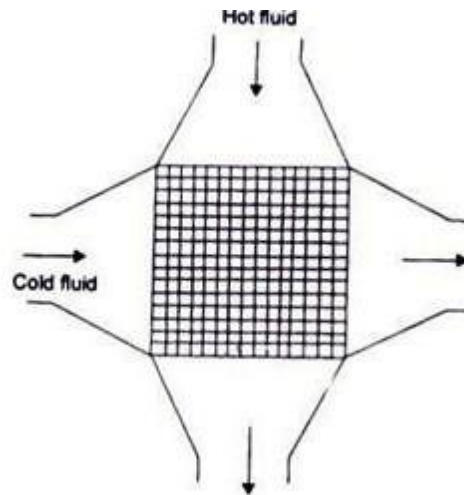

### III.Design and constructional features

- a. Concentric tubes
- b. Shell and tube
- c. Multiple shell and tube passes
- d. Compact heat exchangers

#### a Concentric tubes

Two concentric pipes ,each carrying one of the fluids are used as a heat exchanger.The direction of flow may be parallel or counter.

#### b. Shell and tube

One of the fluids move through a bundle of tubes enclosed by a shell.The other fluid is forced through the shell and it moves over the outside surface of the tubes.

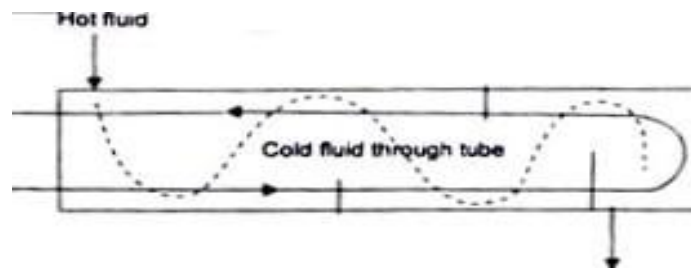

#### c. Multiple shell and tube passes

If the fluid flowing through the tube makes one pass through half of the tube, reverses its direction of flow, and makes a second pass through the remaining half of the tube, it is called 'one-shell-pass, two-tube-pass' heat exchanger. Many other possible flow arrangements exist and are being used. depicts a 'two-shell-pass, four-tube-pass' exchanger.

#### d. Compact heat exchangers

There are many special purpose heat exchangers called compact heat exchangers. They are generally employed when convective heat transfer coefficient associated with one of the fluids is much smaller than that associated with the other fluid.

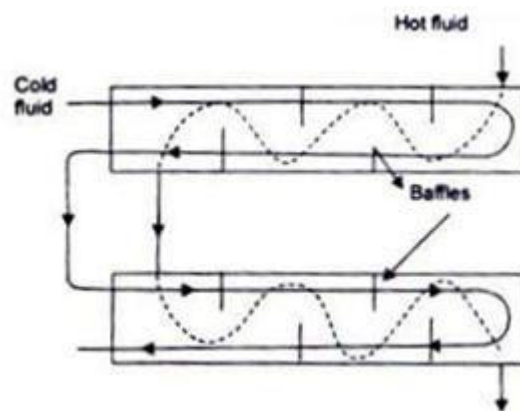

### IV. Physical state of fluids

#### a. Condensers

#### b. Evaporators

#### a) Condenser

In a condenser, the condensing fluid temperature remains almost constant throughout the exchanger and temperature of the colder fluid gradually increases from the inlet to the exit.

b) Evaporator

Temperature of the hot fluid gradually decreases from the inlet to the outlet whereas the temperature of the colder fluid remains the same during the evaporation process. Since the temperature of one of the fluids can be treated as constant, it is immaterial whether the exchanger is parallel flow or counter flow.

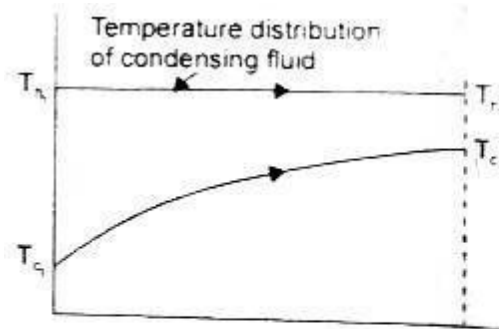

(a) A condenser

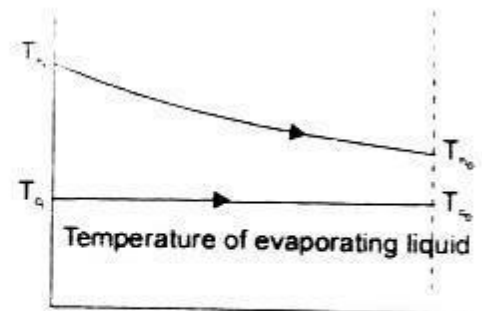

(b) An evaporator

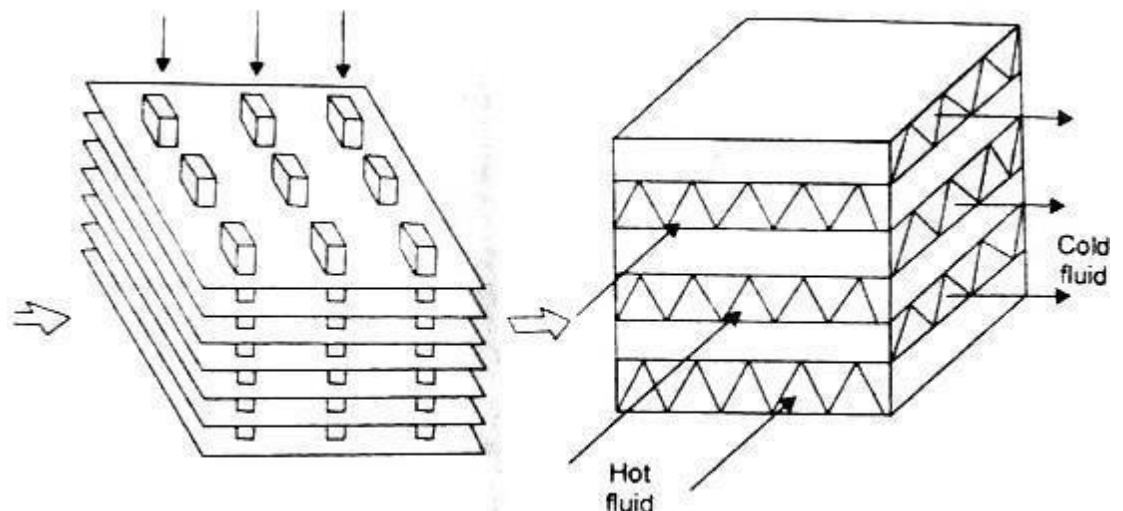

9. Water at the rate of 4 kg/s is heated from 38°C to 55°C in a shell-and-tube heat exchanger. The water is flow inside tube of 2 cm diameter with an average velocity 35 cm/s. How water available at 95°C and at the rate of 2.0 kg/s is used as the heating medium on the shell side. If the length of tubes must not be more than 2m calculate the number of tube passes, the number of tubes per pass and the length of the tubes for one pass shell, assuming  $U_o = 1500 \text{ W/m}^2\text{K}$ .

Given:

$$M_c = 4 \text{ kg/s}$$

$$T_{Cl} = 38^\circ \text{C}$$

$$T_{Co} = 55^\circ \text{C}$$

$$U = 35 \text{ m/s}$$

$$T_{hi} = 95^\circ \text{C}$$

$$C_h = 2 \text{ kg/s}$$

$$U_o = 1500 \text{ W/m}^2\text{K}$$

**To find:**

- 1) Number of tubes per pass
- 2) Number of passes
- 3) Length of tube per pass

**Solution:**

The heat transfer rate for the cold fluid is

$$\begin{aligned} Q &= m_c c_c \Delta T_c \\ &= 4 \times 4186 (55-38) \end{aligned}$$

$$Q = 284.65 \text{ KW}$$

The exit temperature of hot fluid can be calculated

$$\begin{aligned} Q &= m_h C_h \Delta T_h \\ &= 284.65 \text{ kW} \end{aligned}$$

$$\begin{aligned} \Delta T_h &= \frac{284650}{4186 \times 2} \\ &= 34^\circ \text{C} \end{aligned}$$

$$T_{ho} = 95 - 34 = 61^\circ \text{C}$$

Counter flow heat exchanger

$$\Delta T_{ln} = \frac{(\Delta T_1 - \Delta T_2)}{\ln(\Delta T_1 / \Delta T_2)}$$

$$\begin{aligned} \Delta T_1 &= T_{h,i} - T_{c,o} \\ &= 95 - 55 = 40^\circ \text{C} \end{aligned}$$

$$\begin{aligned} \Delta T_2 &= T_{h,o} - T_{c,i} \\ &= 61 - 38 = 23^\circ \text{C} \end{aligned}$$

$$\Delta T_{ln} = \frac{(40 - 23)}{\ln(40/23)} = 30.72^\circ \text{C}$$

$$A = \frac{Q}{U \Delta T_{in}} = 284.65 \times 1000 / ((1500) \times 30.72)$$

$$= 6.177 \text{m}^2$$

Using average velocity of water in the tubes and its flow rates

$$m_c = \rho AU$$

$$A = 4 / [(1000)(0.35)]$$

$$A = 0.011429 \text{m}^2$$

This area is can also be put as the number of tubes

$$0.011429 = n \pi \frac{d^2}{4}$$

$$n = 36.38$$

Taking  $n = 36$ , the total surface area of tubes for one shell pass exchanger in terms of L,

$$A = 6.177 = n \pi d L$$

$$L = 6.177 / [(36) \pi (0.02)]$$

$$L = 2.731 \text{m}$$

Since this length is grater than the permitted length of 2m,

$$P = \frac{t_o - t_i}{T_I - t_i}$$

$$= 0.3$$

$$R = \frac{T_I - T}{t_o - t_i}$$

$$R = 2$$

Thus the total area required for one shall pass, 2 tube pass exchanger is

$$A' = Q / [U F \Delta T_{in}]$$

$$A' = 6.863 \text{m}^2$$

Due to velocity requirement let the number of tubes pr pass still be 36

$$A' = 2 n \pi d l$$

$$L = 6.863 / [2 \times 36 \times \pi \times 0.02]$$

$$L = 1.517 \text{m}$$

1. A nickel wire carrying electric current of 1.5 mm diameter and 50 cm long, is submerged in a water bath which is open to atmospheric pressure. calculate the voltage at the burn out point, if at this point the wire carries a current of 200A.

Given:

$$D = 1.5 \text{ mm} = 1.5 \times 10^{-3} \text{ m}$$

$$L = 50 \text{ cm} = 0.50 \text{ m}$$

$$\text{Current, } I = 200 \text{ A.}$$

To find:

Voltage (v)

Solution:

We know that, saturation temperature of water is  $100^\circ \text{C}$ .

i.e.,  $T_{\text{sat}} = 100^\circ \text{C}$ .

PROPERTIES OF WATER AT  $100^\circ \text{C}$ .

From HMT Data book page no 21

$$\rho_l = 961 \text{ Kg / m}^3$$

$$\nu = 0.293 \times 10^{-6} \text{ m}^2/\text{s}$$

$$P_r = 1.740$$

$$C_{pl} = 4216 \text{ J /Kg k}$$

$$\mu_l = \rho_l \times \nu$$

$$= 961 \times 0.293 \times 10^{-6}$$

$$= 281.57 \times 10^{-6} \text{ Ns/ m}^2$$

From steam table at  $100^\circ \text{C}$ .

$$h_{fg} = 2256.9 \text{ KJ/Kg}$$

$$h_{fg} = 2256.9 \times 10^3 \text{ J/Kg}$$

$$\nu_g = 1.673 \text{ m}^3/\text{Kg}$$

$$\rho_v = 1/\nu_g = 1/1.673$$

$$= 0.597 \text{ Kg / m}^3$$

$\zeta$  = surface tension for liquid – vapour interface

At  $100^\circ \text{C}$  ( From HMT databook page no 144)

$$\zeta = 0.0588 \text{ N/m}$$

For Nucleate pool boiling critical heat flux ( at burn out)

$$Q/A = 0.18 * h_{fg} * \rho_v [ ((\zeta * g * (\rho_l - \rho_v)) / (\rho_v^2))]^{0.25}$$

From HMT databook page no 142

Substitute  $h_{fg}$ ,  $\rho_l$ ,  $\zeta$ ,  $\rho_v$

$$Q/A = 0.18 * 2256.9 * 10^3 * 0.5978 [ ((0.0588 * 9.81 * (961 - 0.597)) / (0.597)^2)]$$

$$Q/A = 1.52 * 10^6 \text{ W/m}^2.$$

Heat transferred,  $Q = V * 1$

$$Q/A = (V * 1) / A$$

$$1.52 * 10^6 = (V * 200) / (\pi d L)$$

$$1.52 * 10^6 = ((V * 200) / (\pi * 1.5 * 10^{-3} * 0.50))$$

$$V = 17.9 \text{ Volts}$$

**2. An oil cooler of the form of tubular heat exchanger cools oil from a temperature of 90° C to 35° C by a large pool of stagnant water assumed at constant temperature of 28° C. The tube length is 32 m and diameter is 28 mm. The specific heat and specific gravity of the oil are 2.45 KJ / Kg K and 0.8 respectively. The velocity of the oil is 62 cm / s. Calculate the overall heat transfer co - efficient.**

Given:

Hot fluid - oil

Cold fluid - water

( T1, T2)

(t1, t2)

Entry temperature of oil T1 = 90° C

Exit temperature of oil T2 = 35° C

Entry and Exit temperature of water, t1 = t2 = 28° C

Tube length L = 32 m

Diameter D = 28 mm = 0.028 m

Specific heat of oil,  $C_{ph} = 2.45 \text{ KJ/Kg k} = 2.45 * 10^3 \text{ J/Kg k}$

Specific gravity of oil = 0.8

Velocity of oil, C = 62 cm / s = 0.62 m/s.

To Find:

Overall heat transfer co-efficient U

Solution:

Specific gravity of oil = Density of oil / density of water

$$= \rho_o / \rho_w$$

$$0.8 = \rho_o / 1000$$

$$\rho_o = 800 \text{ Kg / m}^3.$$

Mass flow rate of oil,  $m_h = \rho_o * A * C$

$$= 800 * ((\pi/4)*(D^2)*0.62$$

$$= 800 * ((\pi/4)*(0.028^2)*0.62$$

$$m_h = 0.305 \text{ Kg / s.}$$

Heat transfer ,  $Q = m_h * C_{ph} * (T_1 - T_2)$

$$= 0.305 * 2.45 * 10^3 * (90 - 35)$$

$$Q = 41 * 10^3 \text{ W.}$$

We know that

$$\text{Heat transfer , } Q = UA (\Delta T)_m$$

From HMT databook page no 151

$(\Delta T)_m$  = logarithmic mean temperature difference ( LMTD)

For parallel flow

$$(\Delta T)_m = [((T_1 - t_1) - (T_2 - t_2))] / \ln [ ((T_1 - t_1) / (T_2 - t_2) )]$$

$$= [((90 - 28) - (35 - 28))] / \ln [ ((90 - 28) / (35 - 28) )]$$

$$(\Delta T)_m = 25.2^\circ \text{ C.}$$

Substitute  $(\Delta T)_m$  value in Q Equation

$$Q = UA (\Delta T)_m$$

$$41 * 10^3 = U * \pi * D * L * (\Delta T)_m$$

$$41 * 10^3 = U * \pi * 0.028 * 32 * 25.2$$

$$U = 577.9$$

Overall heat transfer co-efficient ,  $U = 577.9 \text{ W / m}^2 \text{ K}$

# UNIT 4

## UNIT: IV RADIATION

### 1. State Planck's distribution law. (Nov/Dec 2013)

The relationship between the monochromatic emissive power of a black body and wave length of a radiation at a particular temperature is given by the following expression, by Planck.

$$E_{b\lambda} = \frac{C \lambda^{-5}}{e^{\left(\frac{C_2}{\lambda T}\right) - 1}}$$

Where

$$c_1 = 0.374 \times 10^{-15} \text{ W m}^2$$

$$c_2 = 14.4 \times 10^{-3} \text{ mK}$$

### 2. State Wien's displacement law & Stefan - Boltzmann law. (Nov/Dec 2010)

The Wien's law gives the relationship between temperature and wave length corresponding to the maximum spectral emissive power of the black body at that temperature.

$$\lambda_{\max} T = 2.9 \times 10^{-3} \text{ mK}$$

The emissive power of a black body is proportional to the fourth power of absolute temperature.

$$E_b = \sigma T^4$$

Where  $\sigma$  = Stefan - Boltzmann constant

$$= 5.67 \times 10^{-8} \text{ W/m}^2\text{K}^4$$

$$\Rightarrow E_b = (5.67 \times 10^{-8}) (2773)^4$$

$$E_b = 3.35 \times 10^6 \text{ W/m}^2$$

### 3. State Kirchoff's law of radiation. (April/May 2015)

This law states that the ratio of total emissive power to the absorptivity is constant for all surfaces which are in thermal equilibrium with the surroundings. This can be written as

$$\frac{E_1}{\alpha_1} = \frac{E_2}{\alpha_2} = \frac{E_3}{\alpha_3} \dots\dots\dots$$

It also states that the emissivity of the body is always equal to its absorptivity when the body remains in thermal equilibrium with its surroundings.

$$\alpha_1 = E_1; \alpha_2 = E_2 \text{ and soon.}$$

**4. What is the purpose of radiation shield? (Nov/Dec 2014)**

Radiation shields constructed from low emissivity (high reflective) materials. It is used to reduce the net radiation transfer between two surfaces.

**5. Define irradiation (G) and radiosity (J) (Nov/Dec 2015)**

It is defined as the total radiation incident upon a surface per unit time per unit area. It is expressed in  $W/m^2$ .

It is used to indicate the total radiation leaving a surface per unit time per unit area. It is expressed in  $W/m^2$ .

**6. What are the factors involved in radiation by a body. (Nov /Dec 2014)**

- Wave length or frequency of radiation
- The temperature of surface
- The nature of the surface

**7. What is meant by shape factor?**

The shape factor is defined as the fraction of the radiative energy that is diffused from on surface element and strikes the other surface directly with no intervening reflections. It is represented by Fig. Other names for radiation shape factor are view factor, angle factor and configuration factor.

**8. How radiation from gases differs from solids? (Nov/Dec 2013)**

A participating medium emits and absorbs radiation throughout its entire volume thus gaseous radiation is a volumetric phenomenon, solid radiation is a surface phenomena Gases emit and absorb radiation at a number of narrow wavelength bands. This is in contrast to solids, which emit and absorb radiation over the entire spectrum.

### **9. What is black body and gray body?**

Black body is an ideal surface having the following properties. A black body absorbs all incident radiation, regardless of wave length and direction. For a prescribed temperature and wave length, no surface can emit more energy than black body. If a body absorbs a definite percentage of incident radiation irrespective of their wave length, the body is known as gray body. The emissive power of a gray body is always less than that of the black body.

### **10. Define emissive power [E] and monochromatic emissive power. [Eb<sub>λ</sub>]**

The emissive power is defined as the total amount of radiation emitted by a body per unit time and unit area. It is expressed in W/m<sup>2</sup>.

The energy emitted by the surface at a given length per unit time per unit area in all directions is known as monochromatic emissive power.

### **11. Two parallel radiating Planes 10 x 50 cm are separated by a distance Of 50 cm .what is the radiation shape factor between the planes?(May/June 2012)**

L=100 cm B= 50 cm D= 50 cm [From HMT data book ,Page no.92]

X=L/D=100/50=2 Y=B/D = 50/50=1

From table,for X=2 and Y=1

$$F_{12}=F_{21}=0.28588$$

### **12. What does the view factor represent? When is the view factor from a surface to itself not zero?**

The view factor  $F_{i-j}$  represents the fraction of the radiation leaving surface i that strikes surface j directly. The view factor from a surface to itself is non-zero for concave surfaces.

### **13. State Lambert's cosine law.**

It states that the total emissive power  $E_b$  from a radiating plane surface in any direction proportional to the cosine of the angle of emission

$$E_b \propto \cos \theta$$

**14. Find the temperature of the sun assuming as a Block Body, if the intensity of radiation is maximum at the wavelength of  $0.5\mu$**

According to Wien's displacement law:

$$\lambda_{\max} T = 2.9 \times 10^{-3} \text{ mK}$$

$$0.5 \times 10^{-6} T = 2.9 \times 10^{-3}$$

$$T = 5800 \text{ K}$$

**15. What is a radiation shield? Why is it used?**

Radiation heat transfer between two surfaces can be reduced greatly by inserting a thin, high reflectivity (low emissivity) sheet of material between the two surfaces. Such highly reflective thin plates or shells are known as radiation shields. Multilayer radiation shields constructed of about 20 shields per cm. thickness separated by evacuated space are commonly used in cryogenic and space applications to minimize heat transfer. Radiation shields are also used in temperature measurements of fluids to reduce the error caused by the radiation effect.

**16. State Lamberts cosine law for radiation (April/May 2017)**

It states that the total emissive power  $E_b$  from a radiating plane surface in any direction proportional to the cosine of the angle of emission.  $E_b \propto \cos \theta$

**17. Define monochromatic emissive power (Nov/Dec 2016)**

The monochromatic emissive power  $E_\lambda$ , is defined as the rate, per unit area, at which the surface emits thermal radiation at a particular wavelength  $\lambda$ . Thus the total and monochromatic hemispherical emissive power are related by

$$E = \int_0^\infty E_\lambda d\lambda$$

**18. What is meant by infrared and ultra violet radiation (Nov/Dec 2016)**

Infrared radiation, or simply infrared or IR, is electromagnetic radiation (EMR) with longer wavelengths than those of visible light, and is therefore invisible. Ultraviolet (UV) radiation is a type of radiation that is produced by the sun and some artificial sources, such as solariums

1. Calculate the following for an industrial furnace in the form of a black body and emitting radiation at 2500°C

**Monochromatic emissive power at 1.2 μm wave length.**

- i) **Wave length at which emission is maximum.**
- ii) **Maximum emissive power.**
- iii) **Total emissive power,**
- iv) **The total emissive of the furnace if it is assumed as a real surface having emissivity equal to 0.9. (Nov / Dec 2014) (Nov / Dec 2015)**

**Given:** Surface temperature  $T = 2500^{\circ}\text{C} = 2773\text{K}$

Monochromatic emissive power  $\lambda = 1.2 \times 10^{-6} \text{ m}$

Emissivity = 0.9

**Solution:**

**Step 1. Monochromatic Emissive Power:**

From Planck's distribution law, we know

$$E_{b\lambda} = \frac{C_1 \lambda^{-5}}{e^{\left(\frac{C_2}{\lambda T}\right)} - 1} \quad \text{[From HMT data book, Page No.82]}$$

Where

$$c_1 = 0.374 \times 10^{-15} \text{ W m}^2$$

$$c_2 = 14.4 \times 10^{-3} \text{ mK}$$

$$\lambda = 1.2 \times 10^{-6} \text{ m} \quad \text{[Given]}$$

$$E_{b\lambda} = 5.39 \times 10^{12}$$

**Step 2. Maximum wave length ( $\lambda_{\text{max}}$ )**

From Wien's law, we know

$$\lambda_{\text{max}} T = 2.9 \times 10^{-3} \text{ mK}$$

$$\lambda_{\text{max}} \times 2773 = 2.9 \times 10^{-3} \text{ mK}$$

$$\lambda_{\text{max}} = 5.37 \times 10^{-6}$$

**Step 3. Maximum emissive power ( $E_{b\lambda}$ ) max:**

Maximum emissive power

$$\begin{aligned}(E_{b\lambda})_{\max} &= 1.307 \times 10^{-5} T^5 \\ &= 1.307 \times 10^{-5} \times (2773)^5 \\ (E_{b\lambda})_{\max} &= 2.14 \times 10^{12} \text{ W/m}^2\end{aligned}$$

**Step 4. Total emissive power ( $E_b$ ):**

From Stefan – Boltzmann law, we know that

$$E_b = \sigma T^4 \quad [\text{From HMT data book Page No.72}]$$

Where  $\sigma$  = Stefan – Boltzmann constant

$$= 5.67 \times 10^{-8} \text{ W/m}^2\text{K}^4$$

$$\Rightarrow E_b = (5.67 \times 10^{-8}) (2773)^4$$

$$E_b = 3.35 \times 10^6 \text{ W/m}^2$$

**Step 5. Total emissive power of a real surface:**

$$(E_b)_{\text{real}} = \varepsilon \sigma T^4$$

Where  $\varepsilon$  = Emissivity = 0.9

$$(E_b)_{\text{real}} = 0.9 \times 5.67 \times 10^{-8} (2773)^4$$

$$(E_b)_{\text{real}} = 3.011 \times 10^6 \text{ W/m}^2$$

**2. Two parallel plates of size 1.0 m x 1.0 m spaced 0.5 m apart are located in very large room, the walls are maintained at a temperature of 27°C. one plate is maintained at a temperature of 900°C and other at 400°C. their emissivities are 0.2 and 0.5 respectively. if the plate exchange heat themselves and surroundings, find the heat transfer to each plate and to them. consider only the plate surface facing each other. (May/June 2012 & Nov/Dec 2014)**

**Given:**

Size of the Plate = 1.0 m x 1.0 m

Distance between plates = 0.5 m

Room Temperature,  $T_3 = 27^\circ\text{C} + 273 = 300 \text{ K}$

First plate temperature,  $T_1 = 900^\circ\text{C} + 273 = 1173 \text{ K}$

Second plate temperature ,  $T_2=400^{\circ}\text{C} + 273 =673 \text{ K}$

Emissivity of first plate,  $\epsilon_1 = 0.2$

Emissivity of second plate,  $\epsilon_2 = 0.5$

**To Find:**

1. Net Heat Transfer to each
2. Net heat transfer to room

**Solution:**

In this problem heat exchange take place between two plates and the room .so, this is three surface problem and the corresponding radiation network is given below.

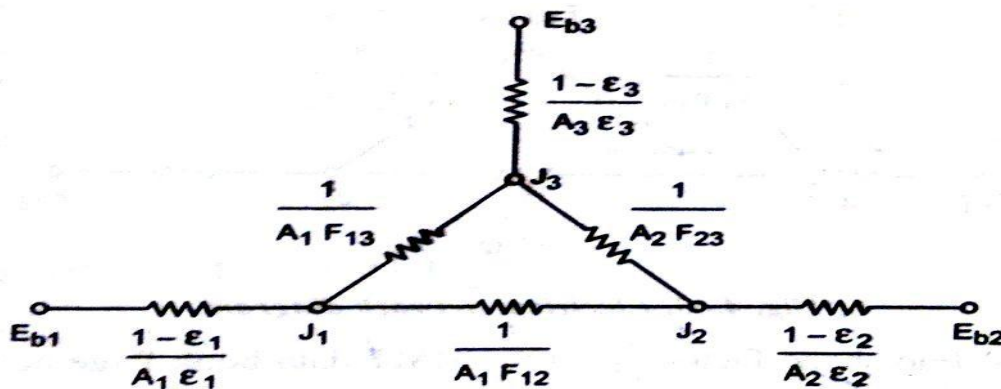

**Electrical network diagram**

Area ,  $A_1 = 1 \times 1 = 1 \text{ m}^2$

$$A_1 = A_2 = 1 \text{ m}^2$$

Since the room is large ,  $A_3 = \infty$

**Step:1** From electrical network diagram,

$$\frac{1 - \epsilon_1}{A_1 \epsilon_1} = \frac{1 - 0.2}{1 \times 0.2} = 4$$

$$\frac{1 - \epsilon_2}{A_2 \epsilon_2} = \frac{1 - 0.5}{1 \times 0.5} = 1$$

$$\frac{1 - \epsilon_3}{A_3 \epsilon_3} = 0 \quad [A_3 = \infty]$$

Apply  $\frac{1 - \epsilon_1}{A_1 \epsilon_1} = 4$ ,  $\frac{1 - \epsilon_2}{A_2 \epsilon_2} = 1$ ,  $\frac{1 - \epsilon_3}{A_3 \epsilon_3} = 0$  values in electrical network diagram.

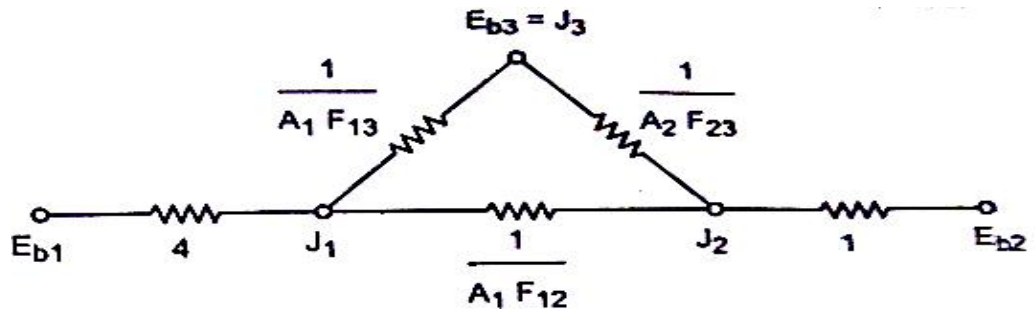

**Electrical network diagram**

**Step:2** To find shape factor  $F_{12}$ , refer HMT data book page no.92 and 93

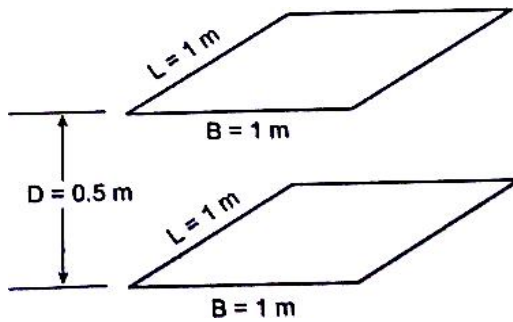

$$X = \frac{L}{D} = \frac{1}{0.5} = 2$$

$$Y = \frac{B}{D} = \frac{1}{0.5} = 2$$

X value is 2, Y value is 2. From that, we can find corresponding shape factor value is 0.41525 [From the table]

i.e  $F_{12} = 0.41525$

we know that,

$$F_{11} + F_{12} + F_{13} = 1, \text{ we know that } F_{11} = 0$$

$$F_{13} = 1 - 0.41525$$

$$F_{13} = 0.5847$$

Similarly,  $F_{21} + F_{22} + F_{23} = 1$  We know that,  $F_{22} = 0$

$$\begin{aligned} F_{23} &= 1 - F_{21} \\ &= 1 - F_{12} = 1 - 0.41525 \\ &= 0.5847 \end{aligned}$$

From electrical network diagram,

$$\frac{1}{A_1 F_{13}} = \frac{1}{1 \times 0.5847} = 1.7102$$

$$\frac{1}{A_2 F_{23}} = \frac{1}{1 \times 0.5847} = 1.7102$$

$$\frac{1}{A_1 F_{12}} = \frac{1}{1 \times 0.41525} = 2.408$$

**Step: 3** From stefan-Boltzmann Law,

$$E_b = \zeta T^4$$

$$E_{b1} = \zeta T_1^4$$

$$= 5.67 \times 10^{-8} [1173]^4$$

$$E_{b1} = 107.34 \times 10^3 \text{ W/m}^2$$

$$E_{b2} = \zeta T_2^4$$

$$= 5.67 \times 10^{-8} [673]^4$$

$$E_{b2} = 11.63 \times 10^3 \text{ W/m}^2$$

$$E_{b3} = \zeta T_3^4$$

$$= 5.67 \times 10^{-8} [300]^4$$

$$E_{b3} = 459.27 \text{ W/m}^2$$

From the electrical network diagram , we know that

$$E_{b3} = J_3 = 459.27 \text{ W/m}^2$$

**Step: 4**

The radiosities  $J_1$  and  $J_2$  can be calculated by using Krichoff's

The sum of current entering the node  $J_1$  is zero.

At Node  $J_1$ :

$$\frac{E_{b1} - J_1}{4} + \frac{J_2 - J_1}{\frac{1}{A_1 F_{12}}} + \frac{E_{b3} - J_1}{\frac{1}{A_1 F_{13}}} = 0 \quad [\text{From electrical network diagram}]$$

$$\frac{107.34 \times 10^3 - J_1}{4} + \frac{J_2 - J_1}{2.408} + \frac{459.27 - J_1}{1.7102} = 0$$

$$26835 - 0.25J_1 + 0.415J_2 - 0.415J_1 + 268.54 - 0.5847J_1 = 0$$

$$-1.2497 J_1 + 0.415 J_2 = -27.10 \times 10^3 \text{-----(1)}$$

At Node  $J_2$ :

$$\frac{J_1 - J_2}{\frac{1}{A_1 F_{12}}} + \frac{E_{b3} - J_2}{\frac{1}{A_2 F_{23}}} + \frac{E_{b2} - J_2}{1} = 0$$

$$\frac{J_1 - J_2}{2.408} + \frac{459.27 - J_2}{1.7102} + \frac{11.63 \times 10^3}{1} = 0$$

$$0.415 J_1 - 1.4997 J_2 = -11.898 \times 10^3 \text{-----(2)}$$

Solving the equation (1) and (2)

$$-1.2497 J_1 + 0.415 J_2 = -27.10 \times 10^3$$

$$-0.415 J_1 - 1.4997 J_2 = -11.898 \times 10^3$$

---

$$J_1 = 26.780 \times 10^3 \text{ W/m}^2$$

$$J_2 = 15.34 \times 10^3 \text{ W/m}^2$$

### Step: 5

Heat lost by plate (1)  $Q_1 = \frac{E_{b1} - J_1}{\frac{1 - \epsilon_1}{A_1 \epsilon_1}}$  [ From electrical network diagram]

$$= \frac{15.34 \times 10^3 - 26.780 \times 10^3}{\frac{1 - 0.2}{1 \times 0.2}}$$

$$Q_1 = 20.140 \times 10^3 \text{ W}$$

Heat lost by plate (2)  $Q_2 = \frac{J_2 - E_{b2}}{\frac{1 - \epsilon_2}{A_2 \epsilon_2}}$

$$= \frac{15.34 \times 10^3 - 11.05 \times 10^3}{\frac{1 - 0.5}{1 \times 0.5}}$$

$$Q_2 = 3710 \text{ W}$$

Total heat lost by the plates(1) and(2)

$$Q = Q_1 + Q_2$$

$$Q = 20.140 \times 10^3 + 3710$$

$$Q = 23.850 \times 10^3 \text{ W}$$

Total heat received or absorbed by the room

$$Q = \frac{J_1 - J_3}{\frac{1}{A_1 F_{13}}} + \frac{J_2 - J_3}{\frac{1}{A_2 F_{23}}}$$

$$Q = \frac{26.780 \times 10^3 - 459.27}{1.7102} + \frac{11.06 \times 10^3 - 459.27}{1.7102}$$

$$Q = 24.09 \times 10^3 \text{ W}$$

**Result:**

1. Net heat lost by each plates

$$Q_1 = 20.140 \times 10^3 \text{ W}$$

$$Q_2 = 3710 \text{ W}$$

2. Net heat transfer to the room

$$Q = 24.09 \times 10^3 \text{ W}$$

**3. Emissivities of two large parallel planes maintained at 800°C and 300°C are 0.3 and 0.5 respectively. Find the net radiant heat exchange per square meter of the plates. Find the percentage of reduction in heat transfer when a polished aluminium shield ( $\epsilon = 0.05$ ) is placed between them. Also find the temperature of the shield (April/May 2015)(Nov/Dec 2015).(NOV/DEC 2013)**

**Given:**

$$T_1 = 800^\circ \text{C} + 273 = 1073 \text{ K}$$

$$T_2 = 300^\circ \text{C} + 273 = 573 \text{ K}$$

$$\epsilon_1 = 0.3$$

$$\epsilon_2 = 0.5$$

$$\text{Radiation shield emissivity } \epsilon_3 = 0.05$$

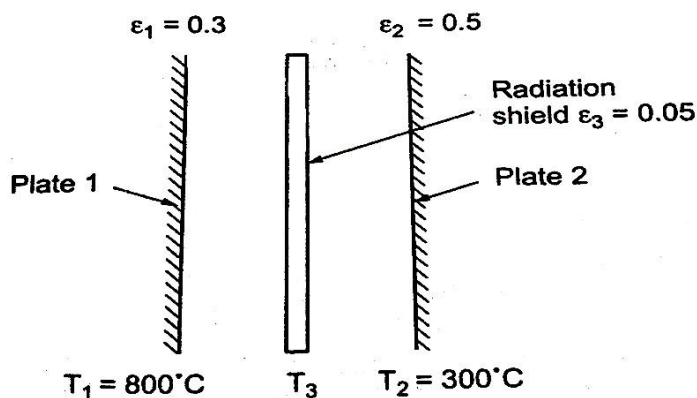

**To find:**

- (i) Percentage of reduction in heat transfer due to radiation shield.
- (ii) Temperature of the shield ( $T_3$ )

**Solution:**

Case: 1 Heat transfer without radiation shield:

Heat exchange between two large parallel plates without radiation shield is given by

$$\text{Step: 1} \quad Q_{12} = \bar{\varepsilon} \sigma A [T_1^4 - T_2^4]$$

$$\text{Where } \bar{\varepsilon} = \frac{1}{\frac{1}{\varepsilon_1} + \frac{1}{\varepsilon_2} - 1}$$
$$= \frac{1}{\frac{1}{0.3} + \frac{1}{0.5} - 1}$$

$$\bar{\varepsilon} = 0.2307$$

$$Q_{12} = 0.2307 \times 5.67 \times 10^{-8} \times A \times [(1073)^4 - (573)^4]$$

**Step: 2**

$$\frac{Q_{12}}{A} = 15.9 \times 10^3 \text{ W/m}^2$$

**Heat transfer without radiation shield**  $\frac{Q_{12}}{A} = 15.9 \times 10^3 \text{ W/m}^2$ ----- (1)

**Case : 2 Heat transfer with radiation shield:**

Heat exchange between radiation plate 1 and radiation shield 3 is given

**Step: 3**

$$Q_{13} = \bar{\varepsilon} \sigma A [T_1^4 - T_3^4]$$

$$\text{Where } \bar{\varepsilon} = \frac{1}{\frac{1}{\varepsilon_1} + \frac{1}{\varepsilon_3} - 1}$$

$$Q_{13} = \frac{\sigma A [T_1^4 - T_3^4]}{\frac{1}{\varepsilon_1} + \frac{1}{\varepsilon_3} - 1}$$
----- (2)

Heat exchange between radiation shield 3 and plate 2 is given

**Step: 4**

$$Q_{32} = \bar{\varepsilon} \sigma A [T_3^4 - T_2^4]$$

$$\text{Where } \varepsilon = \frac{1}{\frac{1}{\varepsilon_3} + \frac{1}{\varepsilon_2} - 1}$$

$$Q_{32} = \frac{\sigma A [T_3^4 - T_2^4]}{\frac{1}{\varepsilon_3} + \frac{1}{\varepsilon_2} - 1} \quad \text{----- (3)}$$

### Step: 5

We know that,

$$Q_{13} = Q_{32}$$

$$\frac{\sigma A [T^4 - T^4]}{\frac{1}{\varepsilon_1} + \frac{1}{\varepsilon_3} - 1} = \frac{\sigma A [T^4 - T^4]}{\frac{1}{\varepsilon_3} + \frac{1}{\varepsilon_2} - 1}$$

$$\frac{\sigma A [1073^4 - T_3^4]}{\frac{1}{0.3} + \frac{1}{0.05} - 1} = \frac{\sigma A [T_3^4 - 573^4]}{\frac{1}{0.05} + \frac{1}{0.5} - 1}$$

$$3.02 \times 10^{13} = 43.3 T_3^4$$

$$T_3 = 913.8 \text{ K}$$

### Temperature of the shield $T_3 = 913.8 \text{ K}$

Substitute  $T_3$  value in equation (2) or (3),

$$\text{Heat transfer with radiation shield } Q_{13} = \frac{\sigma A [1073^4 - 913.8^4]}{\frac{1}{0.3} + \frac{1}{0.05} - 1}$$

$$\frac{Q_{13}}{A} = 159.46 \text{ W/m}^2$$

### Step: 6

Percentage of reduction in heat transfer due to radiation shield

$$= \frac{Q_{\text{withoutshield}} - Q_{\text{withshield}}}{Q_{\text{withshield}}}$$

$$= \frac{Q_{12} - Q_{13}}{Q_{12}}$$

$$= \frac{15.8 \times 10^3 - 1594.6}{15.8 \times 10^3} \times 100$$

$$= 0.899 \times 100 \% = 89.9\%$$

**Percentage of reduction in heat transfer due to radiation shield = 89.9%**

4. The area  $A_1$  and  $A_2$  are perpendicular but do not share the common edge .find the shape factor  $F_{1-2}$  for the arrangement. (Nov/Dec 2015).

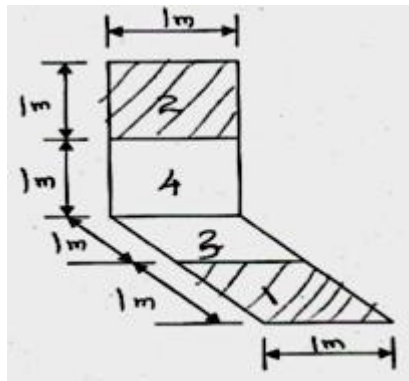

Given:

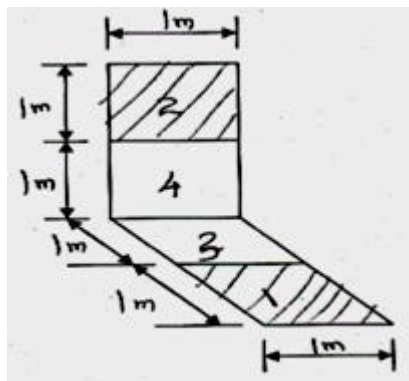

To find : Shape Factor of  $F_{1-2}$

Solution:

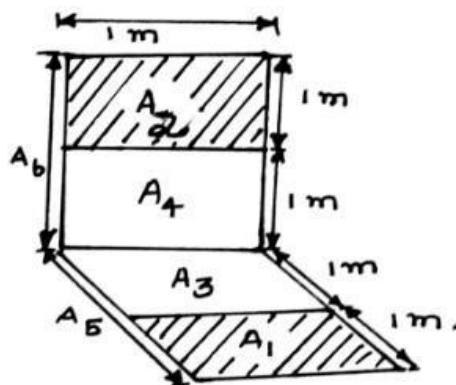

From the figure we know that

**Step: 1**

$$A_5 = A_1 + A_3$$

$$A_6 = A_2 + A_4$$

Further **Step: 2**

$$A_5 F_{5-6} = A_1 F_{1-6} + A_3 F_{3-6}$$

$$[A_5 = A_1 + A_3, F_{5-6} = F_{1-6} + F_{3-6}]$$

$$= A_1 F_{1-2} + A_1 F_{1-4} + A_3 F_{3-6} \quad [F_{1-6} = F_{1-2} + F_{1-4}]$$

$$A_5 F_{5-6} = A_1 F_{1-2} + A_5 F_{5-4} - A_3 F_{3-4} + A_3 F_{3-6} \quad [A_1 = A_5 - A_3, F_{1-4} = F_{5-4} - F_{3-4}]$$

$$A_1 F_{1-2} = A_5 F_{5-6} - A_5 F_{5-4} + A_3 F_{3-4} - A_3 F_{3-6}$$

$$F_{1-2} = \frac{A_5}{A_1} [F_{5-6} - F_{5-4}] + \frac{A_3}{A_1} [F_{3-4} - F_{3-6}] \text{-----(1)}$$

[Refer HMT data book, Page no.95]

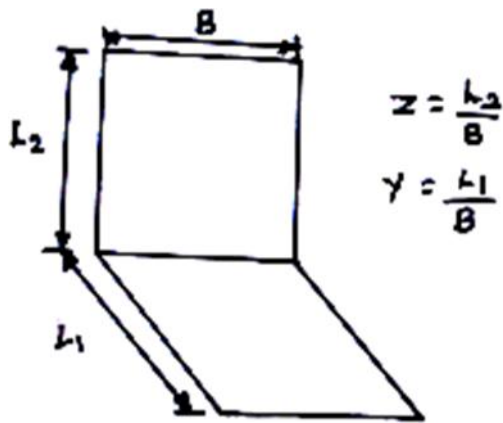

$$Z = \frac{L_2}{B}, Y = \frac{L_1}{B}$$

Step: 3

Shape Factor for the area  $A_5$  and  $A_6$

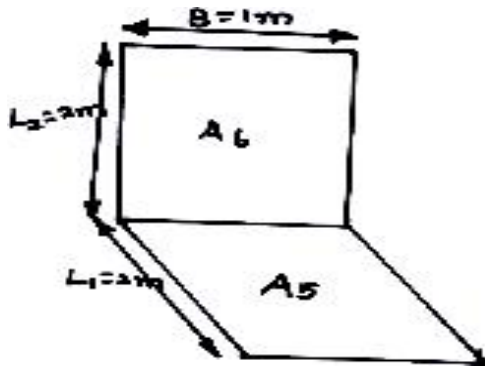

$$Z = \frac{L_2}{B} = \frac{2}{1} = 2$$

$$Y = \frac{L_1}{B} = \frac{2}{1} = 2$$

Z value is 2, Y value is 2. From that, we can find Corresponding shape factor value is 0.14930

$$F_{5-6} = 0.14930$$

### Shape Factor for the area $A_5$ and $A_4$

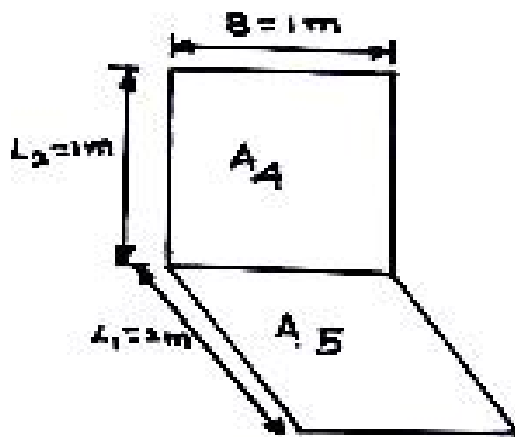

$$Z = \frac{L_2}{B} = \frac{1}{1} = 1$$

$$Y = \frac{L_1}{B} = \frac{2}{1} = 2$$

Z value is 1, Y value is 2. From that, we can find Corresponding shape factor value is 0.11643

$$F_{5-4} = 0.11643$$

### Shape Factor for the area $A_3$ and $A_4$

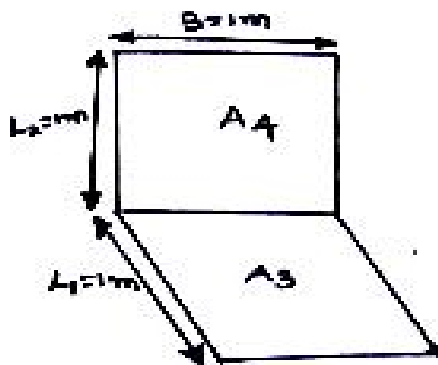

$$Z = \frac{L_2}{B} = \frac{1}{1} = 1$$

$$Y = \frac{L_1}{B} = \frac{1}{1} = 1$$

Z value is 1, Y value is 1. From that, we can find Corresponding shape factor value is 0.2004

$$F_{3-4} = 0.2004$$

**Shape Factor for the area A<sub>3</sub> and A<sub>6</sub>:**

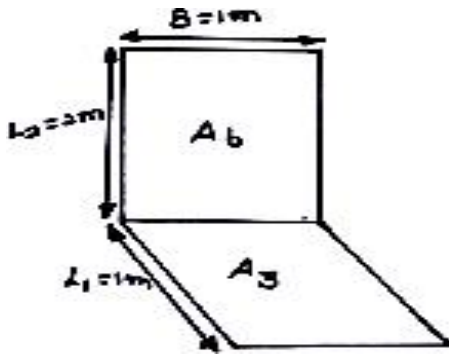

$$Z = \frac{L_2}{B} = \frac{2}{1} = 2$$

$$Y = \frac{L_1}{B} = \frac{1}{1} = 1$$

Z value is 2, Y value is 1. From that, we can find Corresponding shape factor value is 0.23285

$$F_{3-6} = 0.23285$$

**Step: 4**

Substitute F<sub>3-6</sub>, F<sub>3-4</sub>, F<sub>5-4</sub> and F<sub>5-6</sub> in equation (1)

$$F_{1-2} = \frac{A_5}{A_1} [F_{5-6} - F_{5-4}] + \frac{A_3}{A_1} [F_{3-4} - F_{3-6}]$$

$$A_5 = 2 ; A_3 = A_1 = 1$$

$$F_{1-2} = \frac{2}{1} [0.14930 - 0.11643] + \frac{1}{1} [0.2004 - 0.23285]$$

$$F_{1-2} = 0.03293$$

$$F_{1-2} = 0.03293$$

**5. (a) State and Prove Kirchhoff's law of thermal radiation.**

This law states that the ratio of total emissive power to the absorptivity is constant for all surfaces which are in thermal equilibrium with the surroundings.

$$\frac{E_1}{\alpha_1} = \frac{E_2}{\alpha_2} = \frac{E_3}{\alpha_3} \dots\dots\dots$$

It also states that the emissivity of the body is always equal to its absorptivity when the body remains in thermal equilibrium with its surroundings.

$$\alpha_1 = E_1 ; \alpha_2 = E_2 \text{ and soon.}$$

**(b) What is a black body? A 20 cm diameter spherical ball at 527°C is suspended in the air. The ball closely approximates a black body. Determine the total black body emissive power, and spectral black body emissive power at a wavelength of 3 μm.**

A black body absorbs all incident radiation, regardless of wave length and direction. For a prescribed temperature and wave length, no surface can emit more energy than black body.

**Given:**

In sphere, (Black body)

Diameter of sphere,  $d = 20 \text{ cm} = 0.2 \text{ m}$

Temperature of spherical ball,  $T = 527^\circ\text{C} + 273 = 800 \text{ K}$

**To Find:**

- (i) Total black body emissive power,  $E_b$
- (ii) Spectral black body emissive power at wavelength of 3 μm.

**Solution:**

(i) **Step:1** Total black body emissive power,  $E_b$

$$E_b = \sigma AT^4 = 5.67 \times 10^{-8} \times \pi \times (0.2)^2 \times (800)^4$$

$$E_b = 2920 \text{ W}$$

(ii) **Step:2** Spectral black body emissive power: at  $\lambda = 3 \mu\text{m}$

$$E_{b\lambda} = \frac{C_1}{\lambda^5 \left[ \exp\left(\frac{C_2}{\lambda T}\right) - 1 \right]}$$

$$= \frac{0.374 \times 10^{-15}}{(3 \times 10^{-6})^5 \left[ \exp\left(\frac{14.14 \times 10^{-13}}{3 \times 10^{-6} \times 800}\right) - 1 \right]}$$

$$E_{b\lambda} = 3824.3 \times 10^6 \text{ W/m}^2$$

$E_{b\lambda} = 3824.3 \times 10^6 \text{ W/m}^2$
---

**6. Consider a cylinder furnace with outer radius = 1m and height=1 m. The top (surface 1) and the base (surface2) of the furnace have emissivities 0.8 and 0.4 and are maintained at uniform temperature of 700 K and 500 K**

respectively. The side surface closely approximates a black body and is maintained at a temperature of 400 K. Find the net rate of radiation heat transfer at each surface during steady state operation. (May/June 2015)

**Given:**

- Radius of the cylinder = 1 m
- Height of the cylinder = 1 m
- Top surface temperature  $T_1 = 700$  K
- Base surface temperature  $T_2 = 500$  K
- side surface temperature  $T_3 = 400$  K
- Top surface emissivities  $\epsilon_1 = 0.8$
- Base surface emissivities  $\epsilon_2 = 0.4$

**To Find:**

- Net rate of radiation heat transfer at each surface

**Solution:**

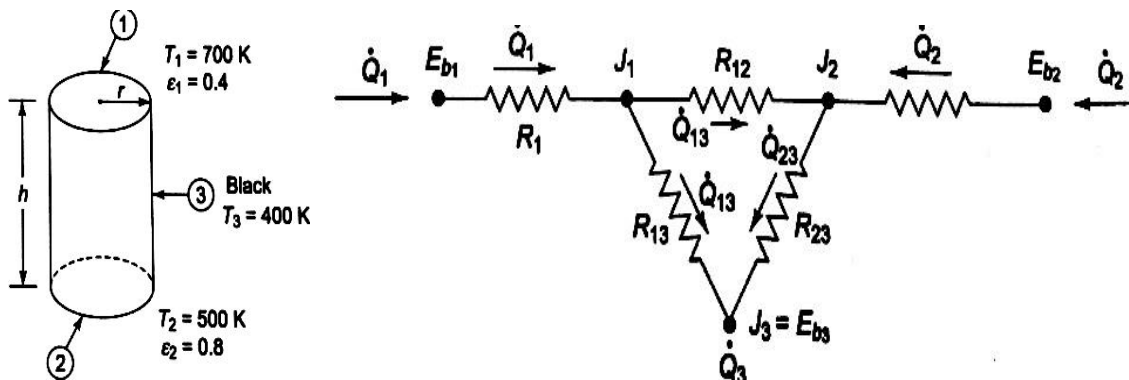

The furnace and the radiation network are shown in above figure .writing the energy balance for the node 1 and 2,

**Step: 1**

$$\frac{E_{b1} - J_1}{R_1} = \frac{J_1 - J_2}{R_{12}} + \frac{J_1 - J_3}{R_{13}} \text{----- (1)}$$

$$\frac{E_{b2} - J_2}{R_2} = \frac{J_2 - J_1}{R_{12}} + \frac{J_2 - J_3}{R_{23}} \text{----- (2)}$$

$$E_{b1} = \sigma T_1^4 = 5.67 \times 10^{-8} (700)^4 = 13614 \text{ W/m}^2$$

$$E_{b2} = \sigma T_2^4 = 5.67 \times 10^{-8} (500)^4 = 3544 \text{ W/m}^2$$

$$E_{b3} = \sigma T_3^4 = 5.67 \times 10^{-8} (400)^4 = 1452 \text{ W/m}^2$$

$$A_1 = A_2 = \Pi r^2 = \Pi(1)^2 = 3.14 \text{ m}^2$$

### Step: 2

From the HMT data Book [page no. 91]

The view factor from the base to top is found to be  $F_{12} = 0.38$

Now,  $F_{11} + F_{12} + F_{13} = 1$ , we know that  $F_{11} = 0$

$$F_{13} = 1 - F_{12} = 1 - 0.38 = 0.62$$

$$R_1 = \frac{1 - \epsilon_1}{A_1 \epsilon_1} = \frac{1 - 0.8}{3.14 \times 0.8} = 0.0796 \text{ m}^2$$

$$R_2 = \frac{1 - \epsilon_2}{A_2 \epsilon_2} = \frac{1 - 0.4}{3.14 \times 0.4} = 0.4777 \text{ m}^2$$

$$R_{12} = \frac{1}{A_1 F_{12}} = \frac{1}{3.14 \times 0.38} = 0.8381 \text{ m}^2$$

$$R_{23} = \frac{1}{A_2 F_{23}} = \frac{1}{3.14 \times 0.62} = 0.5137 \text{ m}^2 = R_{13}$$

### Step: 3

On substitution, of this value in above equation(1) and (2)

$$\frac{13614 - J_1}{0.0796} = \frac{J_1 - J_2}{0.8381} + \frac{J_1 - 1452}{0.5137}$$

$$\frac{3544 - J_2}{0.4777} = \frac{J_2 - J_1}{0.8381} + \frac{J_2 - 1452}{0.5137}$$

By solving the above equations,

$$J_1 = 11418 \text{ W/m}^2 \text{ and } J_2 = 4562 \text{ W/m}^2$$

$$Q_1 = \frac{E_{b1} - J_1}{R_1} = \frac{13614 - 11418}{0.0796} = 27,588 \text{ W}$$

$$Q_2 = \frac{E_{b2} - J_2}{R_2} = \frac{3544 - 4562}{0.4777} = 2132 \text{ W}$$

$$Q_3 + \frac{J_1 - J_3}{R_{13}} + \frac{J_2 - J_3}{R_{23}} = 0$$

$$Q_3 = \frac{1452 - 11418}{0.5137} + \frac{1452 - 4562}{0.5137} = 25455 \text{ W}$$

**Net rate of radiation heat transfer at each surface**

$$Q_1 = 27,588 \text{ W}$$

$$Q_2 = 2132 \text{ W}$$

$$Q_3 = 25455 \text{ W}$$

7. The spectral emissivity function of an opaque surface at 1000 K is approximated as

$$\epsilon_{\lambda 1} = 0.4, 0 \leq \lambda < 2 \mu\text{m};$$

$$\epsilon_{\lambda 2} = 0.7, 2 \mu\text{m} \leq \lambda < 6 \mu\text{m};$$

$$\epsilon_{\lambda 3} = 0.3, 6 \mu\text{m} \leq \lambda < \infty$$

Determine the average emissivity of the surface and the rate of radiation emission from the surface, in W/m<sup>2</sup> (Nov / Dec 2015)

**Given:**

Surface temperature = 1000 K

$$\epsilon_{\lambda 1} = 0.4, 0 \leq \lambda < 2 \mu\text{m};$$

$$\epsilon_{\lambda 2} = 0.7, 2 \mu\text{m} \leq \lambda < 6 \mu\text{m};$$

$$\epsilon_{\lambda 3} = 0.3, 6 \mu\text{m} \leq \lambda < \infty$$

**To Find:** Rate of radiation emission from the surface, in W/m<sup>2</sup>

**Solution:**

The average emissivity can be determined by breaking the integral

**Step:1**

$$\begin{aligned} \epsilon(T) &= \frac{\epsilon_1 \int_0^{\lambda_1} E_{b\lambda}(T) d\lambda}{\sigma T^4} + \frac{\epsilon_2 \int_{\lambda_1}^{\lambda_2} E_{b\lambda}(T) d\lambda}{\sigma T^4} + \frac{\epsilon_3 \int_{\lambda_2}^{\infty} E_{b\lambda}(T) d\lambda}{\sigma T^4} \\ &= \epsilon_1 f_{0-\lambda_1}(T) + \epsilon_2 f_{\lambda_1-\lambda_2}(T) + \epsilon_3 f_{\lambda_2-\infty}(T) \\ &= \epsilon_2 f_{\lambda_1} + \epsilon_2 (f_{\lambda_2} - f_{\lambda_1}) + \epsilon_3 (1 - f_{\lambda_2}) \end{aligned}$$

Where  $f_{\lambda_1}$  and  $f_{\lambda_2}$  are black body radiation function corresponding to  $\lambda_1 T$  to  $\lambda_2 T$

**Step:2**

$$\lambda_1 T = 2 \times 1000 = 2000 \mu\text{mK}, f_{\lambda_1} = 0.066728$$

$$\lambda_2 T = 6 \times 1000 = 6000 \mu\text{mK}, f_{\lambda_2} = 0.737818 \text{ [From HMT data Book Page No: 83]}$$

$$\epsilon = 0.4 \times 0.066728 + 0.7(0.737818 - 0.066728) + 0.3(1 - 0.737818)$$

$$\epsilon = 0.5751$$

**Step:3**

$$E = \epsilon \sigma T^4 = 0.5715 \times 5.67 \times 10^{-8} \times (1000)^4$$

$$E = 32608 \text{ W/m}^2$$

$E = 32608 \text{ W/m}^2$
---------------------------

8. The inner sphere of a liquid oxygen container is 400 mm dia., outer sphere is 500 mm dia., both have emissivity 0.05. Determine the rate of liquid oxygen evaporation at  $-183^{\circ}\text{C}$ , when the outer sphere temperature is  $20^{\circ}\text{C}$ . The latent heat of evaporation  $210\text{ KJ/kg}$ . Neglect losses due to other modes of heat transfer. (May/ June 2016)

**Given:**

Inner wall temperature  $T_1 = -183^{\circ}\text{C} + 273 = 90\text{K}$

Outer wall Temperature  $T_2 = 20^{\circ}\text{C} + 273 = 293\text{ K}$

Inner diameter  $D_1 = 400\text{ mm} = 0.4\text{ m} = r_1 = 0.2\text{ m}$

Outer diameter  $D_2 = 500\text{ mm} = 0.5\text{ m} = r_2 = 0.25\text{ m}$

Emissivity,  $\varepsilon_1 = \varepsilon_2 = 0.05$

Latent heat of evaporation =  $210\text{ KJ/kg} = 210 \times 10^3\text{ J/kg}$

**To Find:**

Rate of liquid oxygen evaporation

**Solution:**

$$\text{Heat transfer } Q_{12} = \bar{\varepsilon} \zeta A_1 [T_1^4 - T_2^4]$$

$$\bar{\varepsilon} = \frac{1}{\frac{1}{\varepsilon_1} + \frac{A_1}{A_2} \left( \frac{1}{\varepsilon_2} - 1 \right)}$$

$$A_1 = 4\pi r_1^2 = 4 \times 3.14 \times (0.2)^2 = 0.5026$$

$$A_2 = 4\pi r_2^2 = 4 \times 3.14 \times (0.25)^2 = 0.7853$$

$$= \frac{1}{\frac{1}{0.05} + \frac{0.5026}{0.7853} \left( \frac{1}{0.05} - 1 \right)}$$

$$\bar{\varepsilon} = 0.0310$$

$$Q_{12} = \bar{\varepsilon} \zeta A_1 [T_1^4 - T_2^4]$$

$$= 0.0310 \times 5.67 \times 10^{-8} \times 0.5026 [90^4 - 293^4]$$

$$Q = -6.4529\text{ W}$$

$$\text{Rate of Evaporation} = \frac{\text{heatTransfer}}{\text{LatentHeat}}$$

$$= \frac{6.4529}{210 \times 10^3}$$

$$= 3.07 \times 10^{-5}$$

Rate of liquid oxygen evaporation =  $3.07 \times 10^{-5}$

$$\text{Rate of liquid oxygen evaporation} = 3.07 \times 10^{-5}$$

**9. Derive relation for heat exchange between infinite parallel planes. (May/June 2014).**

The radiant interchange between two infinite parallel gray planes involves no geometry factor, since  $F_{12} = F_{21} = 1.0$ . let us consider two gray planes,

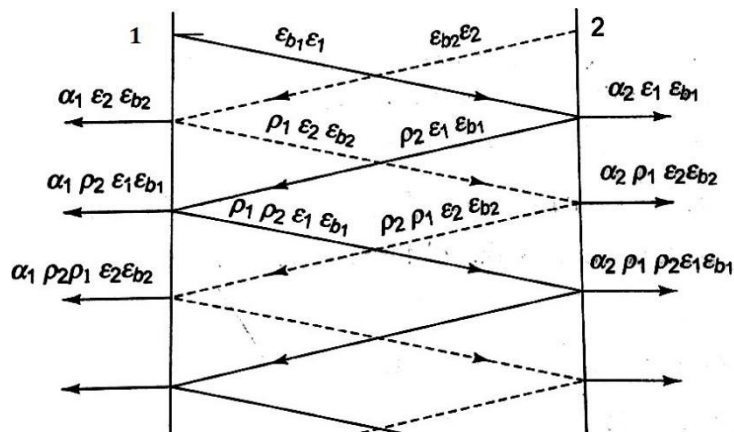

For gray surface  $\alpha = \epsilon$  and  $\rho = 1 - \epsilon$ . Surface 1 emits  $\epsilon_1 E_{b1}$  per unit time and area. surface 2 absorbs  $\alpha_2 \epsilon_2 E_{b2}$  or  $\alpha_2 \epsilon_1 E_{b1}$  and reflects  $\rho_2 \epsilon_1 E_{b1}$  or  $(1 - \epsilon_2) \epsilon_1 E_{b1}$  back towards  $A_1$ . the net heat transferred per unit of surface 1 to 2 is the emission  $\epsilon_1 E_{b1}$  minus the fraction of  $\epsilon_1 E_{b1}$  and  $\epsilon_2 E_{b2}$  which is ultimately absorbed by surface 1 after successive reflections. Therefore.

$$(Q_{1-2})_{net} = \{ A_1 \epsilon_1 E_{b1} [1 - \epsilon_1(1 - \epsilon_2) - \epsilon_1(1 - \epsilon_1)(1 - \epsilon_2)^2 - \epsilon_1(1 - \epsilon_1)^2(1 - \epsilon_2)^3 \dots] \}$$

} -

$$\left\{ A_2 \epsilon_2 E_{b2} \left[ \frac{\epsilon_1 + (1 - \epsilon_2)(1 - \epsilon_1)}{1 - (1 - \epsilon_1)(1 - \epsilon_2)} \right] + \epsilon_1 \left[ \frac{(1 - \epsilon_2) + \epsilon_1 \left[ \frac{(1 - \epsilon_1)^2 (1 - \epsilon_2)^2 + \dots}{1 - (1 - \epsilon_1)(1 - \epsilon_2)} \right]}{1 - (1 - \epsilon_1)(1 - \epsilon_2)} \right] \right\}$$

$$= A \frac{\epsilon_1 \epsilon_2}{\epsilon_1 + \epsilon_2 - \epsilon_1 \epsilon_2} [ E_{b1} - E_{b2} ] \quad \text{since } [A_1 = A_2 = A]$$

$$(Q_{1-2})_{net} = A \sigma \frac{1}{\frac{1}{\epsilon_1} + \frac{1}{\epsilon_2} - 1} (T_1^4 - T_2^4)$$

$$(Q_{1-2})_{net} = A \sigma F_{1-2} (T_1^4 - T_2^4)$$

$$F_{1-2} = \frac{1}{\frac{1}{\epsilon_1} + \frac{1}{\epsilon_2} - 1}$$

$$(Q_{1-2})_{\text{net}} = A \sigma F_{1-2} (T_1^4 - T_2^4)$$

10. A gas mixture contains 20% CO<sub>2</sub> and 10% H<sub>2</sub>O by volume. The total pressure is 2 atm. The temperature of the gas is 927°C. The mean beam length is 0.3 m. Calculate the emissivity of the mixture.

**Given :** Partial pressure of CO<sub>2</sub>, P<sub>CO<sub>2</sub></sub> = 20% = 0.20 atm

Partial pressure of H<sub>2</sub>O, P<sub>H<sub>2</sub>O</sub> = 10% = 0.10 atm.

Total pressure P = 2 atm

Temperature T = 927°C + 273  
= 1200 K

Mean beam length L<sub>m</sub> = 0.3 m

**To find:** Emissivity of mixture (ε<sub>mix</sub>).

**Solution: Step: 1**

**To find emissivity of CO<sub>2</sub>**

$$P_{\text{CO}_2} \times L_m = 0.2 \times 0.3$$

$$P_{\text{CO}_2} \times L_m = 0.06 \text{ m - atm}$$

From HMT data book, Page No.106, we can find emissivity of CO<sub>2</sub>.

From graph, Emissivity of CO<sub>2</sub> = 0.09

$$\epsilon_{\text{CO}_2} = 0.09$$

**Step: 2**

**To find correction factor for CO<sub>2</sub>**

Total pressure, P = 2 atm

$$P_{\text{CO}_2} L_m = 0.06 \text{ m - atm.}$$

From HMT data book, Page No.107, we can find correction factor for CO<sub>2</sub>

From graph, correction factor for CO<sub>2</sub> is 1.25

$$C_{\text{CO}_2} = 1.25$$

$$\epsilon_{\text{CO}_2} \times C_{\text{CO}_2} = 0.09 \times 1.25$$

$$\boxed{\epsilon_{\text{CO}_2} \times C_{\text{CO}_2} = 0.1125}$$

### Step: 3

To find emissivity of H<sub>2</sub>O:

$$P_{\text{H}_2\text{O}} \times L_m = 0.1 \times 0.3$$

$$\boxed{P_{\text{H}_2\text{O}} L_m = 0.03 \text{ m - atm}}$$

From HMT data book, Page No.108, we can find emissivity of H<sub>2</sub>O.

From graph Emissivity of H<sub>2</sub>O = 0.048

$$\boxed{\epsilon_{\text{H}_2\text{O}} = 0.048}$$

### Step: 4

To find correction factor for H<sub>2</sub>O:

$$\frac{P_{\text{H}_2\text{O}} L_m}{2} = \frac{0.1 \times 0.3}{2} = 1.05$$

$$\frac{P_{\text{H}_2\text{O}} L_m}{2} = 1.05,$$

$$P_{\text{H}_2\text{O}} L_m = 0.03 \text{ m - atm}$$

From HMT data book, Page No.108 we can find emission of H<sub>2</sub>O

**1. Two large parallel plates with  $\epsilon = 0.5$  each, are maintained at different temperatures and are exchanging heat only by radiation. Two equally large radiation shields with surface emissivity 0.05 are introduced in parallel to the plates. find the percentage of reduction in net radiative heat transfer.**

Given:

Emissivity of plate 1,  $\epsilon_1 = 0.5$

Emissivity of plate 2,  $\epsilon_2 = 0.5$

Emissivity of shield,  $\epsilon_s = \epsilon_{s1} = \epsilon_{s2} = 0.05$

Number of shields,  $n = 2$

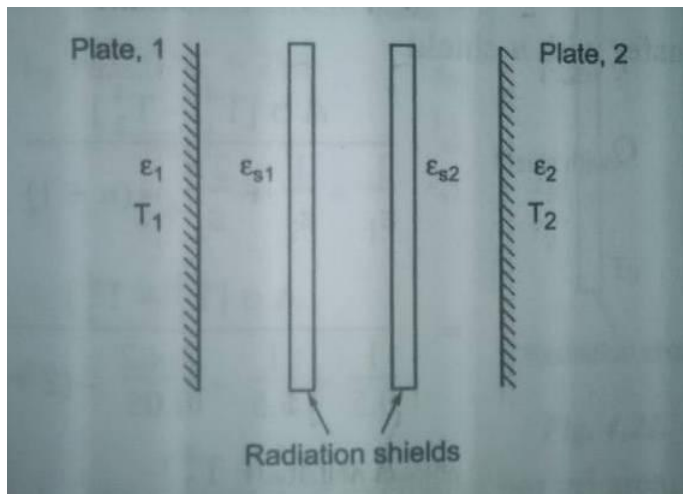

To find:

Percentage of reduction in net radiative heat transfer

Solution:

Case 1:

Heat transfer without radiation shield

$$Q_{12} = \varepsilon * \zeta * A * [T_1^4 - T_2^4]$$

$$\varepsilon = 1 / (((1/ \varepsilon_1) + (1/ \varepsilon_2) - 1))$$

$$\varepsilon = 1 / (((1/ 0.5) + (1/ 0.5) - 1))$$

$$\varepsilon = 0.333.$$

$$Q_{12} = \varepsilon * \zeta * A * [T_1^4 - T_2^4]$$

$$Q_{12} = 0.333 * \zeta * A * [T_1^4 - T_2^4]$$

CASE 2: Heat transfer with radiation shield

$$\begin{aligned} Q_{\text{with shield}} &= (\zeta * A * [T_1^4 - T_2^4]) / ((1/ \varepsilon_1) + (1/ \varepsilon_2) + (2n / \varepsilon_s) - (n+1)) \\ &= (\zeta * A * [T_1^4 - T_2^4]) / ((1/ 0.5) + (1/ 0.5) + ((2*2) / 0.05) - (2+1)) \\ &= (\zeta * A * [T_1^4 - T_2^4]) / 81 \end{aligned}$$

$$Q_{\text{with shield}} = 0.0123 * (\zeta * A * [T_1^4 - T_2^4])$$

We know that

Radiation in heat transfer due to radiation shield

$$\begin{aligned} &= (Q_{\text{WITHOUT SHIELD}} - Q_{\text{WITH SHIELD}}) / Q_{\text{WITHOUT SHIELD}} \\ &= \frac{((0.333 * \zeta * A * [T_1^4 - T_2^4]) - (0.0123 * (\zeta * A * [T_1^4 - T_2^4])))}{(0.333 * \zeta * A * [T_1^4 - T_2^4])} \\ &= 0.963 \end{aligned}$$

= 96.3 %

Percentage of reduction in net radiative heat transfer = 96.3 .

**2. A black body at 3000 K emits radiation Calculate the following**

**1. Monochromatic emissive power at 1 μm wave length**

**2. Wave length at which emission is maximum**

**3. Maximum emissive power**

**4. Total emissive power**

**5. Calculate the total emissive of the furnace if it is assumed as a real surface having emissivity equal to 0.85**

**Given**

Surface temperature T = 3000K

**To find**

1. Monochromatic emissive power  $E_{b\lambda}$  at  $\lambda = 1 \mu = 1 \times 10^{-6}m$

2. Maximum wave length, ( $\lambda_{max}$ )

3. Maximum emissive power ( $E_{b\lambda}$ )<sub>max</sub>

4. Total emissive power,  $E_b$

5. Emissive power of real surface at  $\epsilon = 0.85$

**Solution**

**1. Monochromatic emissive power**

**From Planck's distribution law, we know that**

$$E_{b\lambda} = \frac{c_1 \lambda^{-5}}{\frac{c_2}{e^{\lambda T} - 1}}$$

$$C_1 = 0.374 \times 10^{-15} \text{ Wm}^2$$

$$C_2 = 14.4 \times 10^{-3} \text{ mK}$$

$$\lambda = 1 \times 10^{-6} \text{ m}$$

$$E_{b\lambda} = \frac{0.374 \times 10^{-15} [1 \times 10^{-6}]^{-5}}{\left[ \frac{14.4 \times 10^{-3}}{e^{1 \times 10^{-6} \times 3000} - 1} \right]}$$

$E_{b\lambda} = 3.10 \times 10^{12} \text{ W/m}^2$
--

**2. Maximum wave length ( $\lambda_{max}$ )**

$$\lambda_{max} T = 2.9 \times 10^{-3} \text{ mK}$$

$$\lambda_{\max} = \frac{2.9 \times 10^{-3}}{3000}$$

$$\lambda_{\max} = 0.966 \times 10^{-6} \text{ m}$$

### 3. Maximum emissive power $(E_{b\lambda})_{\max}$

$$\begin{aligned}(E_{b\lambda})_{\max} &= 1.307 \times 10^{-5} T^5 \\ &= 1.307 \times 10^{-5} \times (3000)^5\end{aligned}$$

$$(E_{b\lambda})_{\max} = 3.17 \times 10^{12} \text{ W/m}^2$$

### 4. Total emissive power $E_b$

$$E_b = \sigma \times T^4 \text{ (From HMT data book P.No 8)}$$

$$\sigma = \text{Stefen Boltzman Constant}$$

$$= 5.67 \times 10^{-8} \text{ W/m}^2 \text{ K}^4$$

$$E_b = (5.67 \times 10^{-8}) \times (3000)^4$$

$$E_b = 4.59 \times 10^6 \text{ W/m}^2$$

### 5. Total emissive power of real surface

$$(E_b)_{\text{real}} = \epsilon \sigma T^4$$

$$\epsilon - \text{Emissivity} = 0.85$$

$$(E_b)_{\text{real}} = 0.85 \times 5.67 \times 10^{-8} \times (3000)^4$$

$$(E_b)_{\text{real}} = 3.90 \times 10^6 \text{ W/m}^2$$

### Result

1.  $E_{b\lambda} = 3.10 \times 10^{12} \text{ W/m}^2$  2.  $\lambda_{\max} = 0.966 \times 10^{-6} \mu\text{m}$

3.  $(E_{b\lambda})_{\max} = 3.17 \times 10^{12} \text{ W/m}^2$  4.  $(E_b)_{\text{real}} = 3.90 \times 10^6 \text{ W/m}^2$

# UNIT 5

## UNIT: V MASS TRANSFER

### **1. What is mass transfer?**

The process of transfer of mass as a result of the species concentration difference in a mixture is known as mass transfer.

### **2. Give the examples of mass transfer.**

Some examples of mass transfer.

1. Humidification of air in cooling tower
2. Evaporation of petrol in the carburettor of an IC engine.
3. The transfer of water vapour into dry air.

### **3. What are the modes of mass transfer? (Nov/Dec 2010)(Nov/Dec 2104)**

There are basically two modes of mass transfer,

1. Diffusion mass transfer
2. Convective mass transfer

### **4. What is molecular diffusion?**

The transport of water on a microscopic level as a result of diffusion from a region of higher concentration to a region of lower concentration in a mixture of liquids or gases is known as molecular diffusion.

### **5. What is Eddy diffusion?**

When one of the diffusion fluids is in turbulent motion, eddy diffusion takes place.

### **6. What is convective mass transfer? (May/June 2006)**

Convective mass transfer is a process of mass transfer that will occur between surface and a fluid medium when they are at different concentration.

### **7. State Fick's law of diffusion. (April/May 2012) (NOV-DEC 14)( Nov/Dec 16)**

The diffusion rate is given by the Fick's law, which states that molar flux of an element per unit area is directly proportional to concentration gradient.

$$\frac{ma}{A} = -D_{ab} \frac{dC_a}{dx}$$

Where,

$$\frac{m_a}{A} - \text{Molar flux, } \frac{\text{kg} - \text{mole}}{\text{s} - \text{m}^2}$$

$D_{ab}$ - Diffusion coefficient of species a and b,  $\text{m}^2/\text{s}$

$$\frac{dC_a}{dx} - \text{Concentration gradient, } \text{kg}/\text{m}^3$$

### 8. What is free convective mass transfer?

If the fluid motion is produced due to change in density resulting from concentration gradients, the mode of mass transfer is said to be free or natural convective mass transfer.

Example: Evaporation of alcohol.

### 9. Define forced convective mass transfer.

If the fluid motion is artificially created by means of an external force like a blower or fan, that type of mass transfer is known as convective mass transfer.

Example: The evaporation of water from an ocean when air blows over it.

### 10. Define Schmidt and Lewis number. What is the physical significance of each? (NOV/DEC 13)

The dimensionless Schmidt number is defined as the ratio of momentum diffusivity to mass diffusivity  $Sc = \nu/D_{AB}$ , and it represents the relative magnitudes of momentum and mass diffusion at molecular level in the velocity and concentration boundary layers, respectively. The Schmidt number diffusivity corresponds to the Prandtl number in heat transfer. A Schmidt number of unity indicates that momentum and mass transfer by diffusion are comparable, and velocity and concentration boundary layers almost coincide with each other.

The dimensionless Lewis number is defined as the ratio of thermal diffusivity to mass diffusivity  $Le = \alpha / D_{AB}$  and it represents the relative magnitudes of heat and mass diffusion at molecular level in the thermal and concentration boundary layers, respectively. A Lewis number of unity indicates that heat and mass diffuse at the same rate, and the thermal and concentration boundary layers coincide.

**11. Define Sherwood Number. (April/May 2012)**

It is defined as the ratio of concentration gradients at the boundary.

$$Sc = \frac{hmX}{D_{ab}}$$

hm- Mass transfer coefficient, m/s

D<sub>ab</sub>-Diffusion coefficient, m<sup>2</sup>/s

X- length, m

**12. What is mass average velocity?( May/June 2010)**

The bulk velocity of mixture, in which different components may have different mobilities, is compared either on mass average. If a fluid mixture of two components A and B if  $u_A$  and  $u_B$  are the mean velocities then the average velocity is

$$u_{\text{mass}} = (\rho_A u_A + \rho_B u_B) / (\rho_A + \rho_B)$$

**13. Distinguish between mass concentration and molar concentration (April/May 2017)**

Mass Concentration

Mass of a component per unit volume of the mixture. It is expressed in kg/m<sup>3</sup>

$$\text{Mass concentration} = \frac{\text{Mass of a component}}{\text{Unit volume of mixture}}$$

Molar concentration

Number of molecules of a component per unit volume of the mixture. It is expressed in Kg - mole /m<sup>3</sup>

$$\text{Molar concentration} = \frac{\text{Number of moles of component}}{\text{Unit volume of mixture}}$$

**14. Define Schmidt number and state its physical significance. ) ( Nov/Dec 16)**

Schmidt number (Sc) is a dimensionless number defined as the ratio of momentum diffusivity (viscosity) and mass diffusivity, and is used to characterize fluid flows in which there are simultaneous momentum and mass diffusion convection processes.

Significance:

Analogous of Prandtl number in Heat Transfer. Used in fluid flows in which there is simultaneous momentum & mass diffusion. It is also ratio of fluid boundary layer to mass transfer boundary layer thickness.

1. A vessel contains binary mixture of O<sub>2</sub> and N<sub>2</sub> with partial pressure in the ratio 0.21 and 0.79 at 15°C. The total pressure of the mixture is 1.1 bar. Calculate the following.

- I. Molar concentrations
- II. Mass densities
- III. Mass fractions
- IV. Molar fraction of each species.

[APRIL/MAY 2014; NOV/DEC 2015]

**Given:**

Partial pressure of O<sub>2</sub> = 0.21 x total pressure

$$(P_{O_2}) = 0.21 \times 1.1$$

$$P_{O_2} = 0.231 \times 10^5 \text{ N/m}^2$$

So partial pressure of N<sub>2</sub> = P<sub>N<sub>2</sub></sub> = 86.9 x 10<sup>3</sup> N/m<sup>2</sup>

Temperature T = 15° C = 288 K

**To find**

- I. Molar concentrations, C<sub>O<sub>2</sub></sub>, C<sub>N<sub>2</sub></sub>
- II. Mass densities, ρ<sub>O<sub>2</sub></sub>, ρ<sub>N<sub>2</sub></sub>
- III. Mass fractions, m<sub>O<sub>2</sub></sub>, m<sub>N<sub>2</sub></sub>
- IV. Molar fraction of each species. X<sub>O<sub>2</sub></sub>, X<sub>N<sub>2</sub></sub>

**Solution:**

**STEP-1**

Molar concentration,  $c_{O_2} = \frac{p_{O_2}}{GT}$

Universal Gas Constant, G = 8314 J/kg mole K

$$C_{O_2} = \frac{0.231 \times 10^5}{8314 \times 288}$$

$$C_{O_2} = 9.64 \times 10^{-3} \text{ kg-mole/m}^3$$

$$C_{N_2} = \frac{P_{N_2}}{GT}$$

$$C_{N_2} = \frac{86.9 \times 10^3}{8314 \times 288}$$

$$C_{N_2} = 0.036 \text{ kg-mole/m}^3$$

Total concentration,

$$C = C_{O_2} + C_{N_2} = 0.045 \text{ kg mole/m}^3$$

### STEP-2

Molar concentration

$$C = \frac{\rho}{\mu}$$

$$\rho_{O_2} = C_{O_2} \times \mu_{O_2}$$

$$= 9.64 \times 10^{-3} \times 32$$

$$\rho_{O_2} = 0.308 \text{ kg/m}^3$$

$$= 0.0362 \times 28$$

$$\rho_{N_2} = 1.013 \text{ kg/m}^3$$

Overall density,  $\rho = \rho_{O_2} + \rho_{N_2}$

$$= 0.308 + 1.0136$$

$$\rho = 1.3216 \text{ kg/m}^3$$

### STEP-3

$$\text{Mass fractions } \dot{m}_{O_2} = \frac{\rho_{O_2}}{\rho} = \frac{0.308}{1.3216}$$

$$\dot{m}_{O_2} = 0.233$$

$$\dot{m}_{N_2} = \frac{\rho_{N_2}}{\rho} = \frac{1.0136}{1.3216}$$

$$\dot{m}_{N_2} =$$

### 0.766 STEP-4

$$\text{Mole fractions, } X_{O_2} = \frac{C_{O_2}}{C} = \frac{9.64 \times 10^{-3}}{0.045}$$

$$X_{O_2} = 0.210$$

$$X_{N_2} = \frac{C_{N_2}}{C} = \frac{0.0362}{0.045}$$

$$X_{O_2} = 0.804$$

**RESULT:**

I. Molar concentrations,  $C_{O_2} = 9.64 \times 10^{-3} \text{ kg-mole/m}^3$

$$C_{N_2} = C_{N_2} = 0.036 \text{ kg-mole/m}^3$$

II. Mass densities,  $\rho_{O_2} = 0.308 \text{ kg/m}^3$

$$\rho_{N_2} = 1.013 \text{ kg/m}^3$$

III. Mass fractions,  $\dot{m}_{O_2} = 0.233$

$$\dot{m}_{N_2} = 0.766$$

IV. Molar fraction of each species.  $X_{O_2} = 0.210$

$$X_{N_2} = 0.804$$

2. Air at 20°C ( $\rho = 1.205 \text{ kg/m}^3$ ;  $\nu = 15.06 \times 10^{-6} \text{ m}^2/\text{s}$ ;  $D = 4.16 \times 10^{-6} \text{ m}^2/\text{s}$ ) flows over a tray (length = 32 cm, width = 42 cm) full of water with a velocity of 2.8 m/s. The total pressure of moving air is 1 atm and the partial pressure of water present in the air is 0.00658 bar. If the temperature on the water surface is 15°C calculate the evaporation rate of water.

(MAY/JUNE 2012; NOV/DEC 2014; NOV/DEC 2015; APRIL/MAY 2016)

**Given:**

Fluid temperature,  $T_\infty = 20^\circ\text{C}$

Speed,  $U = 2.8 \text{ m/s}$

Flow direction is 32 cm side. So,  $x = 32 \text{ cm} = 0.32 \text{ m}$

Area,  $A = 32 \text{ cm} \times 42 \text{ cm} = 0.32 \times 0.42 \text{ m}^2$

Partial pressure of water,  $P_{w_2} = 0.0068 \text{ bar}$

$$P_{w_2} = 0.0068 \times 10^5 \text{ N/m}^2$$

Water surface temperature,  $T_w = 15^\circ\text{C}$

**To find:**

Evaporation rate of water ( $M_w$ )

**Solution:**

Properties of air is given

$$\rho = 1.205 \text{ kg/m}^3;$$

$$\nu = 15.06 \times 10^{-6} \text{ m}^2/\text{s};$$

Diffusion coefficient  $D = 4.16 \times 10^{-6} \text{ m}^2/\text{s}$

### STEP-1

$$\text{Re} = \frac{UL}{\nu} = \frac{2.8 \times 0.32}{15.06 \times 10^{-6}}$$
$$= 0.594 \times 10^5 < 5 \times 10^5$$

Since  $\text{Re} < 5 \times 10^5$ , flow is laminar

Flat plate laminar flow:

$$\text{Sherwood number (Sh)} = [0.664 (\text{Re})^{0.5} (\text{Sc})^{0.333}] \dots \dots \dots \{1\}$$

[From HMT data book, P.no-175]

### STEP-2

$$\text{Sc} \rightarrow \text{Schmidt number} = \frac{\nu}{D_{ab}} = \frac{15.06 \times 10^{-6}}{4.16 \times 10^{-5}}$$

$$\text{Sc} = 0.3620$$

Sub Sc, Re in {1}

$$(\text{Sh}) = [0.664 (0.594 \times 10^5)^{0.5} (0.3620)^{0.333}]$$

$$\text{Sh} = 115.37$$

### STEP-3

$$\text{Sherwood number Sh} = \frac{h_m L}{D_{ab}}$$

$$115.37 = \frac{h_m 0.32}{4.16 \times 10^{-5}}$$

$$h_m = 0.0149 \text{ m/s}$$

### STEP-4

Mass transfer coefficient based on pressure difference is given

$$h_{mp} = \frac{h_m}{RT_w} = \frac{0.0149}{287 \times 288} \quad [T_w = 15^\circ\text{C} + 273 = 288 \text{ K, So } R = 287 \text{ J/kg K}]$$

$$h_{mp} = 1.80 \times 10^{-7} \text{ m/s}$$

Saturation pressure of water at  $15^\circ\text{C}$

$$P_{w1} = 0.017 \text{ bar}$$

$$P_{w1} = 0.017 \times 10^5 \text{ N/m}^2 \quad [\text{From steam table (R.S khurmi) P.no-1}]$$

### STEP-5

The evaporation of water

$$M_w = h_{mp} \times A (P_{w1} - P_{w2})$$

$M_w = 2.66 \times 10^{-5} \text{ kg/s}$
--

**Result:**

The evaporation rate of water  $M_w = 2.66 \times 10^{-5} \text{ kg/s}$

3. **Dry air at 27°C and 1 atm flows over a wet flat plate 50 cm long at a velocity of 50 m/s. Calculate the mass transfer coefficient of water vapour in air at the end of the plate.**

**(NOV/DEC 2014; APRIL/MAY 2015) (NOV/DEC**

**Given:**

Fluid temperature  $T_\infty = 27^\circ\text{C}$

Velocity  $u = 50 \text{ m/s}$

Length  $x = 35 \text{ mm} = 0.035 \text{ m}$

**To find:**

Mass transfer co-efficient, ( $h_m$ )

**Solution:**

**STEP-1**

Properties of air at 27°C:

$$V = 16 \times 10^{-6} \text{ m}^2/\text{s}$$

$$\text{Re} = \frac{UL}{\nu} = \frac{50 \times 0.035}{16 \times 10^{-6}}$$

$$= 1.09375 \times 10^5 < 5 \times 10^5$$

Since  $\text{Re} < 5 \times 10^5$ , flow is laminar

Flat plate laminar flow:

$$\text{Sherwood number (Sh)} = [0.664 (\text{Re})^{0.5} (\text{Sc})^{0.333}] \dots \dots \dots \{1\}$$

[From HMT data book, P.no-175]

**STEP-2**

$$[D_{ab} - \text{Diffusion coefficient (water+ air) @ } 27^\circ\text{C} = 25.38 \times 10^{-6} \text{ m}^2/$$

$$Sc \rightarrow \text{Schmidt number} = \frac{\nu}{D_{ab}} = \frac{16 \times 10^{-6}}{25.38 \times 10^{-6}}$$

$$Sc = 0.6304$$

### STEP-3

Sub Sc, Re in {1}

$$(Sh) = [0.664 (1.09375 \times 10^5)^{0.5} (0.6304)^{0.333}]$$

$$Sh = 188.32$$

### STEP-4

$$\text{Sherwood number } Sh = \frac{h_m L}{D_{ab}}$$

$$188.32 = \frac{h_m 0.35}{25.38 \times 10^{-6}}$$

$$h_m = 0.1365 \text{ m/s}$$

### Result:

Mass transfer coefficient of water vapour  $h_m = 0.1365 \text{ m/s}$ .

4. **CO<sub>2</sub> and air experience equimolar counter diffusion in a circular tube whose length and diameter are 1 m and 50 mm respectively. The system of total pressure of 1 atm and a temperature of 25°C. The ends of the tube are connected to large chambers in which the species concentrations are maintained at fixed values. the partial pressure of CO<sub>2</sub> at one end is 190 mm of Hg while at the other end is 95 mm Hg. Estimate the mass transfer rate of CO<sub>2</sub> and air through the tube.**

*[MAY/JUNE 2012; APRIL/MAY 2016]*

### Given:

Diameter,  $d = 50 \text{ mm} = 0.05 \text{ m}$

Length =  $1 \text{ m}$  [ $x_2 - x_1$ ]

Total pressure,  $p = 1 \text{ atm} = 1 \text{ bar}$

Temperature,  $T = 25^\circ\text{C} = 298 \text{ K}$

Partial pressure of CO<sub>2</sub> at one end

$$P_{a1} = 190 \text{ mm of Hg} = \frac{190}{760} \text{ bar}$$

$$P_{a1} = 0.25 \text{ bar} \quad [1 \text{ bar} = 760 \text{ mm of Hg}]$$

$$P_{a1} = 0.25 \times 10^5 \text{ N/m}^2 \quad [1 \text{ bar} = 10^5 \text{ N/mm}^2]$$

Partial pressure of CO<sub>2</sub> at other end

$$P_{a2} = 95 \text{ mm of Hg} = \frac{95}{760} \text{ bar}$$

$$P_{a2} = 0.0312 \text{ bar} \quad [1 \text{ bar} = 760 \text{ mm of Hg}]$$

$$P_{a2} = 0.0312 \times 10^5 \text{ N/m}^2 \quad [1 \text{ bar} = 10^5 \text{ N/mm}^2]$$

**To find:**

1. Mass transfer rate of CO<sub>2</sub>
2. Mass transfer rate of air

**Solution:**

**STEP-1**

$$\frac{m_a}{A} = \frac{D_{ab} [C_{a1} - C_{a2}]}{GT [X_2 - X_1]}$$

Diffusion coefficient (D<sub>ab</sub>) for CO<sub>2</sub>-Air combination is  $11.89 \times 10^{-6} \text{ m}^2/\text{s}$

[HMT data book page no.180]

$$G = \text{Universal gas constant} = 8314 \frac{\text{J}}{\text{kg-mole-K}} \quad (\text{J/kg-mole-K})$$

$$A = \text{Area} = \frac{\pi}{4} (d)^2$$

$$A = 1.9634 \times 10^{-3} \text{ m}^2$$

$$\frac{m_a}{A} = \frac{D_{ab} [C_{a1} - C_{a2}]}{GT [X_2 - X_1]}$$

$$\frac{m_a}{A} = \frac{11.89 \times 10^{-6} [0.25 \times 10^5 - 0.0312 \times 10^5]}{8314 \times 298 [1]} \quad [1]$$

$$\text{Molar transfer rate of CO}_2, m_a = 1.050 \times 10^{-7} \frac{\text{kg-mole}}{\text{s}}$$

**STEP-2**

We know,

Mass Transfer Rate CO<sub>2</sub> = Molar Transfer x Molecular Weight

$$= 1.050 \times 10^{-7} \times 44.01$$

[Molecular weight of CO<sub>2</sub> Refer HMT D.B Page 182]

$$\text{Mass Transfer Rate CO}_2 = 4.625 \times 10^{-6} \text{ kg/s}$$

$$\text{Mass Transfer Rate of Air} = m_b = -1.050 \times 10^{-7} \frac{\text{kg} - \text{mole}}{\text{s}}$$

### STEP-3

$$[m_a = -m_b]$$

Mass Transfer Rate Air = Molar Transfer x Molecular Weight of air

$$= 1.050 \times 10^{-7} \times 29$$

$$\text{Mass Transfer Rate Air} = -3.045 \times 10^{-6} \text{ kg/s}$$

### Result:

1. Mass transfer rate of Co<sub>2</sub> =  $4.625 \times 10^{-6} \text{ kg/s}$

2. Mass transfer rate of air =  $-3.045 \times 10^{-6} \text{ kg/s}$

### 5. Discuss briefly the Analogy between heat and mass transfer.

*[MAY/JUNE 2013; NOV/DEC 2015; APRIL/MAY 2016]*

There is similarity among heat and mass transfer. The three basic equations dealing with these are

- I. Newtonian equation of momentum
- II. Fourier law of heat transfer
- III. Fick law of mass transfer

The momentum, heat and mass transfer equation can be written as

$$\text{Continuity equation, } \frac{\partial u}{\partial x} + \frac{\partial v}{\partial y} = 0$$

$$\text{Momentum transfer, } u \frac{\partial u}{\partial x} + v \frac{\partial v}{\partial y} = \nu \frac{\partial^2 u}{\partial y^2}$$

$$\text{Heat transfer, } u \frac{\partial T}{\partial x} + v \frac{\partial T}{\partial y} = \alpha \frac{\partial^2 T}{\partial y^2}$$

$$\text{Mass transfer, } u \frac{\partial C_a}{\partial x} + v \frac{\partial C_a}{\partial y} = D \frac{\partial^2 C_a}{\partial y^2}$$

Heat and mass transfer takes place due to temperature difference. As per Fourier's law of conduction

$$Q = -kA \frac{dt}{dx}$$

Where Q= rate of heat transfer

K= thermal conductivity of material

A= Heat transfer area

$\frac{dt}{dx}$  = Temperature gradient

As per Newton's law of cooling

$$Q = hA\Delta T$$

Where h= heat transfer coefficient

Mass transfer takes place due to concentration difference.

As per Fick's law of diffusion

$$Na = \frac{m_A}{A} = -D_{AB} \frac{dC_A}{dx}$$

$m_A$  = Mass flow rate of species A by diffusion.

A = Area through which mass is flowing

$D_{AB}$  = Diffusion coefficient.

$\frac{dC_A}{dx}$  = concentration gradient.

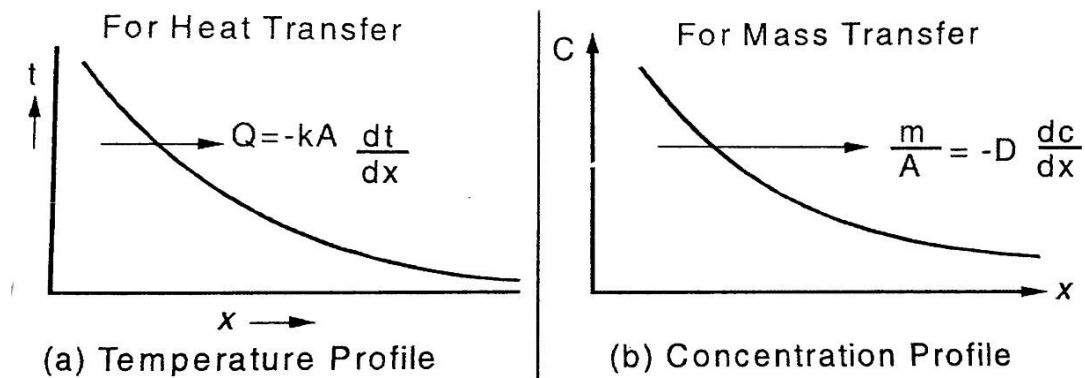

## 6. Explain Equimolar Counter diffusion in gases.

[APRIL/MAY 2013; NOV/DEC 2014]

Two large chambers 'a' and 'b' connected by a passage as shown below.

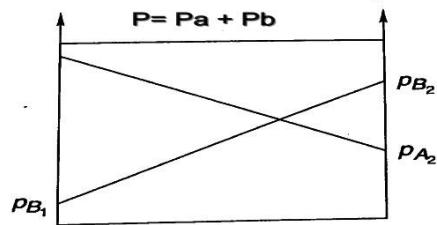
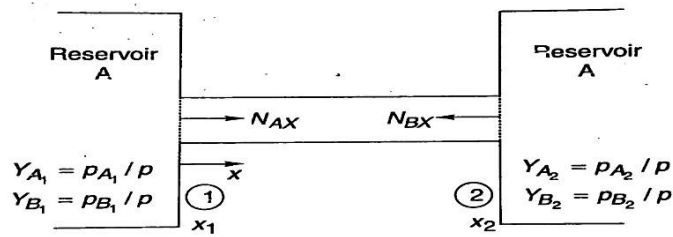

Equimolar Counter Diffusion in a Binary Mixture

$N_a$  and  $N_b$  are the steady state molar diffusion rates of component a and b respectively.

Equimolar diffusion is defined as each molecule of 'a' is replaced by each molecule of 'b' and vice versa. The total pressure  $p = p_a + p_b$  is uniform throughout the system.

$$P = P_a + P_b$$

Differentiating with respect to x

$$\frac{dP}{dx} = \frac{dP_a}{dx} + \frac{dP_b}{dx}$$

Since the total pressure of the system remains constant under steady state conditions

$$\frac{dP}{dx} = \frac{dP_a}{dx} + \frac{dP_b}{dx} = 0$$

$$\frac{dP_a}{dx} = -\frac{dP_b}{dx}$$

Let the total molar flux is zero,  $N_a + N_b = 0$

$$\rightarrow N_a = -N_b$$

From Fick's law,

$$-D_{BA} \frac{A}{GT} \frac{dP_a}{dx} = D_{BA} \frac{A}{GT} \frac{dP_b}{dx}$$

$$D_{AB} = D_{BA} = D$$

$$N_a = \frac{m_a}{A} = -D \frac{A}{GT} \int_1^2 \frac{dP_a}{dx}$$

Molar flux, 
$$N_a = \frac{ma}{A} = -D \frac{A}{GT} \left[ \frac{Pa_1 - Pa_2}{x_2 - x_1} \right]$$

Similarly,

$$N_b = \frac{mw}{A} = -D \frac{A}{GT} \left[ \frac{Pb_1 - Pb_2}{x_2 - x_1} \right]$$

Where,

$$\frac{ma}{A} - \text{Molar flux} \frac{\text{kg} - \text{mole}}{\text{s} - \text{m}^2}$$

D- Diffusion coefficient

$$G - \text{Universal constant} - 8314 \frac{J}{\text{kg} - \text{mole} - K}$$

A- Area - m<sup>2</sup>

Pa1- Partial pressure of constituent at 1 in N/m<sup>2</sup>

Pa2- Partial pressure of constituent at 2 in N/m<sup>2</sup>

T - Temperature - K

**7. An open pan of 150 mm diameter and 75 mm deep contains water at 25°C and is exposed to atmosphere air at 25°C and 50°C R.H. calculate the evaporation rate of water in grams per hour.**

**[APRIL/MAY 2002]**

**Given:**

Diameter, d = 150 mm = 0.150 m

Deep, (x<sub>2</sub>-x<sub>1</sub>) = 75 mm = 0.075 m

Temperature, T = 25°C+273 = 298 K

Relative Humidity = 50%

**To Find:**

Evaporation rate of water in grams per hour.

**Solution:**

Diffusion co-efficient (D<sub>ab</sub>) [water + air] at 25°C

[From HMT data book, page no, 180]

$$D_{ab} = 25.83 \times 10^{-6} \text{ m}^2/\text{s}$$

### STEP-1

We know that, for isothermal evaporation,

$$\text{Molar flux, } \frac{ma}{A} = \frac{D_{ab}}{GT} \frac{p}{(x_2 - x_1)} \ln \left[ \frac{P - P_{w2}}{P - P_{w1}} \right]$$

$$\text{Area, } A = 0.0176 \text{ m}^2$$

$$P = \text{Total pressure} = 1 \text{ atm} = 1.013 \times 10^5$$

$$\text{N/mm}^2$$

$P_{w1}$  = Partial pressure at the bottom of the test tube corresponding to saturation temperature 25°C.

At 25°C

$$\rightarrow P_{w1} = 0.03166 \times 10^5 \text{ N/mm}^2$$

[From steam table p.no 2]

$P_{w2}$  = Partial pressure at the top of the pan corresponding to 25°C and 50°C relative humidity.

At 25°C

$$\rightarrow P_{w2} = 0.03166 \times 10^5$$

$$\text{R.H} = 50\% = 0.50$$

$$P_{w2} = 0.03166 \times 10^5 \times 0.50$$

$$\rightarrow P_{w2} = 1583 \text{ N/m}^2$$

### STEP-2

$$\frac{ma}{0.076} = \frac{25.83 \times 10^{-6}}{8314 \times 298} \times \frac{1.013 \times 10^5}{0.075} \ln \left[ \frac{1.013 \times 10^5 - 1583}{1.013 \times 10^5 - 0.03166 \times 10^5} \right]$$

$$\text{Molar rate of water vapour, } ma = 3.96 \times 10^{-9} \frac{\text{kg-mole}}{\text{s}}$$

### STEP-3

Mass rate of water vapour = molar rate of water vapour X molecular weight of steam

$$= 3.96 \times 10^{-9} \times 18.016 \text{ kg/s}$$

$$\text{Mass rate of water vapour} = 0.256 \text{ g/h}$$

**Result:**

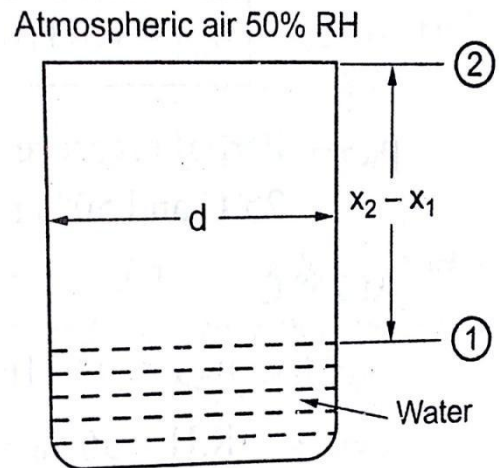

Evaporation rate of water = 0.256 g/h.

Evaporation rate of water = 0.256 g/h.

1. Two large tanks, maintained at the same temperature and pressure are connected by a circular 0.15m diameter duct, which is 3 m length. One tank contains a uniform mixture of 60 mole % ammonia and 40 mole % air and other tank contains a uniform mixture of 20 mole % ammonia and 80 mole % air. The system is at 273 K and  $1.013 \times 10^5$  pa. Determine the rate of ammonia transfer between the two tanks. Assuming a steady state mass transfer.

Given:

$$\text{Diameter } d = 0.15 \text{ m}$$

$$\text{Length } (x_2 - x_1) = 3 \text{ m}$$

$$P_{a1} = \frac{60}{40} = 0.6 \text{ bar} = 0.6 \times 10^5 \text{ N/m}^2$$

$$P_{b1} = \frac{40}{40} = 0.4 \text{ bar} = 0.4 \times 10^5 \text{ N/m}^2$$

$$P_{a2} = \frac{20}{40} = 0.2 \text{ bar} = 0.2 \times 10^5 \text{ N/m}^2$$

$$P_{b2} = \frac{80}{40} = 0.8 \text{ bar} = 0.8 \times 10^5 \text{ N/m}^2$$

$$T = 273 \text{ K}$$

$$P = 1.013 \times 10^5 \text{ N/m}^2$$

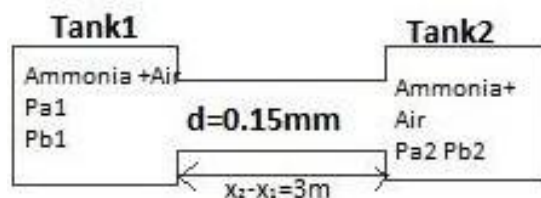

a-Ammonia

b-Air

**To find**

Rate of ammonia transfer

**Solution:**

## Equimolar counter diffusion

### Molar flux,

$$\frac{m_a}{A} = \frac{D_{ab}}{GT} \left[ \frac{P a_1 - P a_2}{X_2 - X_1} \right]$$

Where G - universal constant = 8314 J/Kg-mole-K

$$A = \text{area} = \frac{\pi}{4} d^2$$

$$A = \frac{\pi}{4} (0.15)^2$$

$$A = 0.017 \text{ m}^2$$

$D_{ab}$ -Diffusion coefficient of ammonia with air =  $21.6 \times 10^{-6} \text{ m}^2/\text{s}$   
(From HMT data book P.No 180 (sixth edition))

$$D_{ab} = 21.6 \times 10^{-6} \text{ m}^2/\text{s}$$

$$(1) = \frac{m_a}{0.017} = \frac{21.6 \times 10^{-6}}{8314 \times 273} \times \frac{0.6 \times 10^5 - 0.2 \times 10^5}{3}$$

$$\text{Molar transfer rate of ammonia, } m_a = 2.15 \times 10^{-9} \text{ Kg-mole/s}$$

Mass transfer rate of ammonia = Molar transfer rate of ammonia x Molecular weight of ammonia

$$= 2.15 \times 10^{-9} \times 17.03 \text{ (Refer HMT data book P.No 182)}$$

$$\text{Mass transfer rate of ammonia} = 3.66 \times 10^{-8} \text{ Kg/s}$$

### Result

$$\text{Mass transfer rate of ammonia} = 3.66 \times 10^{-8} \text{ Kg/s}$$

**2. An open pan 20cm in diameter and 8 cm deep contains water at 25°C and is exposed to dry atmospheric air. If the rate of diffusion of water vapour is  $8.5 \times 10^{-4} \text{ kg/h}$ , estimate the diffusion coefficient of water in air.**

**Given :**

$$\text{Diameter } d = 20 \text{ cm} = 0.20 \text{ m}$$

$$\text{Length } (x_2 - x_1) = 8 \text{ cm} = 0.08 \text{ m}$$

$$\text{Temperature } T = 25^\circ\text{C} + 273 = 298 \text{ K}$$

Diffusion rate (or)

$$\text{Mass rate of water vapour} = 8.54 \times 10^{-4} \text{ kg/h}$$

$$= \frac{8.54 \times 10^{-4} \text{ kg}}{3600 \text{ s}}$$

$$= 2.37 \times 10^{-7} \text{ kg/s}$$

**To find**

Diffusion coefficient  $D_{ab}$

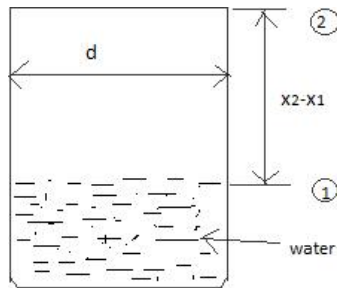

**Solution**

Molar rate of water vapour

$$\frac{m_a}{A} = \frac{D_{ab}}{GT} \frac{p}{x_2 - x_1} \times \ln \left[ \frac{p - p_{w2}}{p - p_{w1}} \right]$$

$$m_a = \frac{D_{ab} \times A}{GT} \frac{p}{x_2 - x_1} \times \ln \left[ \frac{p - p_{w2}}{p - p_{w1}} \right]$$

We know that

Mass transfer rate of steam = Molar transfer rate of steam x Molecular weight of steam

$$2.37 \times 10^{-7} = \frac{D_{ab} \times A}{GT} \frac{p}{x_2 - x_1} \times \ln \left[ \frac{p - p_{w2}}{p - p_{w1}} \right] \times 18.016$$

Where

$$\text{Area } A = \frac{\pi}{4} d^2$$

$$= \frac{\pi}{4} (0.20)^2$$

$$A = 0.0314 \text{ m}^2$$

**G** - universal constant = 8314 J/Kg-mole-K

**P** - Total Pressure = 1 atm = 1.013 bar = 1.013 x 10<sup>5</sup> N/m<sup>2</sup>

**P<sub>w1</sub>**- Partial pressure at the bottom of the test tube corresponding to saturation temperature 25°C

At 25°C (From Rs Khurmi Steam table P.No 2)

$$P_{w1} = 0.03166 \times 10^5 \text{ N/m}^2$$

**P<sub>w2</sub>**- Partial pressure at the top of the pan Hence air is dry and there is no water vapour So,  $P_{w2} = 0$

$$P_{w2} = 0$$

(1) =

$$2.37 \times 10^{-7} = \frac{D_{ab} \times 0.0314}{8314 \times 298} \times \frac{1.013 \times 10^5}{0.08} \times \ln \left[ \frac{1.013 \times 10^5 - 0}{1.013 \times 10^5 - 0.03166 \times 10^5} \right] \times 18.016$$

$$D_{ab} = 2.58 \times 10^5 \text{ m}^2/\text{s}$$

**Result**

Diffusion coefficient,  $D_{ab} = 2.58 \times 10^5 \text{ m}^2/\text{s}$

